

# ST556KWH-D250HV +4xSG125HV

Storage System



## SYSTEM FEATURES

- Fully integrated 1500V DC coupled PV+ESS system with “one stop shop”
- Intelligent MPPT-Charging control algorithm enable the high-efficient operation

## CIRCUIT DIAGRAM

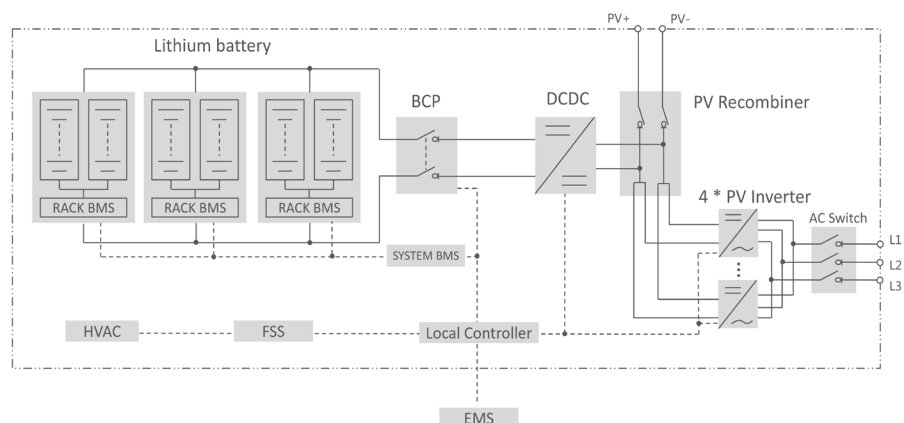

System Type	ST556KWH-D250HV+4xSG125HV
<b>PV Data</b>	
Max PV input voltage	1,500 V
MPPT voltage range at nominal power	860 ~ 1,250 V
Number of DC inputs	5
Max. PV input current	1,250 A
<b>DCDC Data</b>	
Working voltage range	500 ~ 1,500 V
Nominal power	250 kW
Max. current	344 A
<b>Battery Data</b>	
Cell type	Samsung SDI Mega E3, 3.68 V / 100 Ah
Configuration of system	2P252S*3
Battery capacity (BOL)	556 kWh
Battery voltage range	806.4 ~1,045.8 V
<b>AC Data</b>	
AC output power	500kVA @ 50 °C
Max. AC output current	480 A
Nominal AC voltage	3 / PE, 600 V
AC voltage range	480 ~ 690 V
Nominal grid frequency / Grid frequency range	60 Hz / 55 ~ 65 Hz
Power factor at nominal power / Adjustable power factor	> 0.99 / 0.8 leading ~ 0.8 lagging
Feed-in phases / connection phases	3/3
<b>General Data</b>	
Dimensions (W * H * D)	6,058 * 2,896 * 2,438 mm / 238.5" * 114.0" * 96.0"
Weight (with / without battery)	11.0 T / 7.0 T 24,250 lbs / 15,432 lbs
Degree of protection	IP 54 / NEMA 3R
Operating temperature range	-30 to 50 °C / -22 to 122 °F
Relative humidity	0 ~ 95 % (non-condensing)
Max. working altitude	2,000 m / 6,562 ft
Cooling concept of battery chamber	Heating, Ventilation and Air Conditioning
Fire suppression system of battery unit	FM-200 extinguishment system
Communication interfaces	RS485, Ethernet
Communication protocols	Modbus RTU, Modbus TCP
Compliance	UL 9540, UL 9540A