

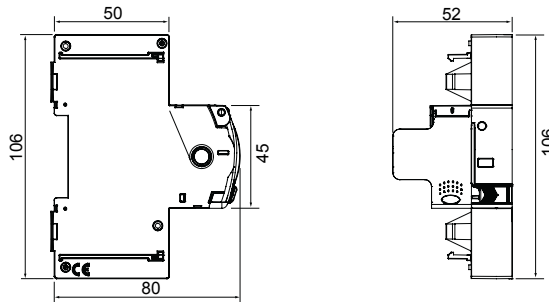

Description Automatic reclosing device  
 Code ReStart Rm PRO 2P  
 Suitable for RCBO's MDC - 1P+N/2P - 100-300 mA  
 Rated voltage AC 230 V  
 Rated current 6 - 10 - 16 - 20 - 25 - 32 A  
 No. modules 1  
 Standard EN 50557  
 Rated frequency (Hz) 50 - 60 Hz

Distribution system	TT - TN-S	Rated non-operating resistance between live parts and earth (Rdo)	2,5 kΩ
Insulation voltage (Ui)	500 V	Rated operating resistance between live parts and earth (Rd)	5 kΩ
Rated impulse withstand voltage (Uimp)	4 kV	Maximum operating frequency	30 oper./h
Overvoltage category	III	Mechanical endurance	4000
Dielectric strength test voltage between pole and earth	2500 Vac for 1 minute	Type of residual current protection	AC - A - A[S]
Rated residual operating current	300 mA	Operating temperature	-5 +60 °C
Stocking temperature	-40°C ÷ +70°C	Automatic reclosure for untimely tripping	Yes
Earth failure test	Yes	Continuous system monitoring	Yes
Completeable with	GWD0951 Auxiliary contact - GW90992 RS485 BUS Module	Number of poles	2P
Electrocod	1414		

### DIMENSIONAL



### STANDARDS/APPROVALS

