



Description Interruttore automatico scatolato
 Code MSX 250
 No. of poles 3P
 Rated current 250 A
 Release Electromechanic

ELECTRICAL CHARACTERISTICS

Standard	IEC/EN 60947-2
Use category	A
Rated frequency (Hz)	50 / 60
Rated operating voltage (Ue)	690 Vac - 250 Vdc
Rated impulse withstand voltage (Uimp)	8 kV
Oversvoltage category	IV
Insulation voltage (Ui)	800 V
Thermal regulation	0,63 - 0,8 - 1 x In
Magnetic regulation	6 - 8 - 10 x In
Neutral protection	-
Total power loss	48.75 W
Rated short-circuit current making capacity (Icm)	-
Rated short-time withstand current for 0,3s (Icw)	-
I _{dn} regulation	-
DT regulation	-

SERVICE BREAKING CAPACITY (ICU)

220/240Vac	65 kA
400/415Vac	36 kA
440Vac	25 kA
525Vac	25 kA
690Vac	7,5 kA
250Vdc	40 kA

MECHANICAL CHARACTERISTICS

Execution	Fixed - Plug-in
DIN rail mounting	Yes, by means of accessory
Can be equipped with motor operator	Yes
Compatible interlock	Lever - Cable
Terminals supplied	Front FC
Assembly position	Any
Upline/downline power supply	Yes
Electrical life (415Vac)	10.000 cycles
Mechanical life	30.000 cycles
Operating temperature	-5°C +65°C
Stocking temperature	-20° +65°
Weight (kg)	1.5
Width	105 mm
Height	165 mm
Depth	68 mm

RATED BREAKING CAPACITY (ICS)

220/240Vac	65 kA	220/240Vac	65 kA
400/415Vac	36 kA	400/415Vac	36 kA
440Vac	25 kA	440Vac	25 kA
525Vac	25 kA	525Vac	25 kA
690Vac	7,5 kA	690Vac	7,5 kA
250Vdc	40 kA	250Vdc	40 kA

DIMENSIONAL

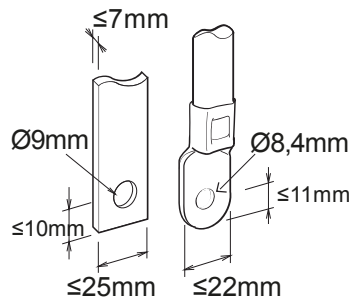



Product Data Sheet

GWD9128

MSX

STANDARDS/APPROVALS

