

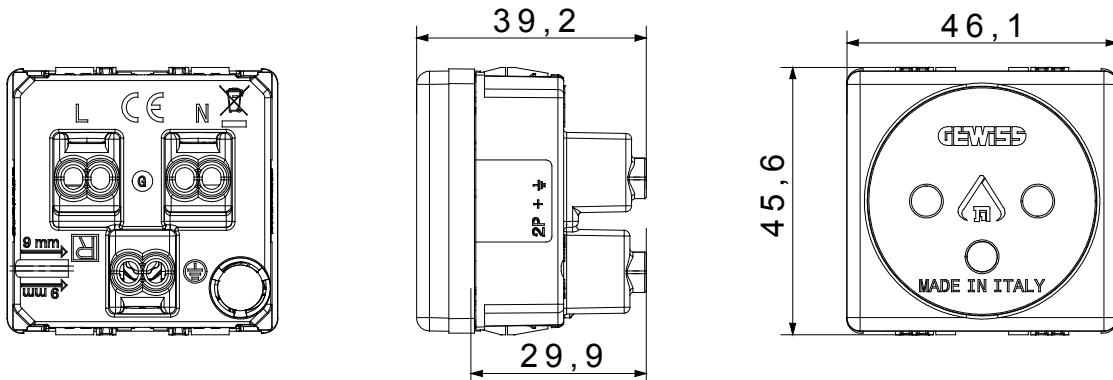

The System modular devices make it possible to create infinite combination between devices and plates, thanks to a complete range that is able to satisfy all design, functional and installation requirements. Colour and finish: glossy white, bright and versatile
 Ideal for flush-mounting solutions (for rectangular or square boxes), surface-mounting solutions, and for special applications. The range includes commands, socket-outlets, protection, indicators, connectors and devices for the control, safety and comfort of your home.

Category	Socket-Outlet	Description	2P+E - 16A
Colour	White	Voltage	250 V ac
Earth pit	-	Standard	Israeli
Characteristics	With safety shields	For plug pins	Round Ø 4 / 4.4 mm
Wiring terminals	With screw	Type	-
Standard	IEC 60884-1; SI 32 part 1.1	Resistance at test voltage	2000 V at 50 Hz for 1 minute
Insulation resistance	> 5 MOhm	Prolonged operation switch (no.of position changes)	10.000 at In 250 V ac cosφ=0,8
Thermo-pressure with ball	125 °C	Glow Wire Test	850 °C
Terminal grip on cable traction	> 50 N	Terminal tightening capacity stranded cables (mm ²)	min. 0,75 - max. 2x4
Terminal tightening capacity solid cables (mm ²)	min. 0,5 - max. 2x2,5	No. SYSTEM modules	2
Material	Technopolymer	Electrocod	0131

DIMENSIONAL



TECHNICAL SYMBOLOGY



STANDARDS/APPROVALS

