

OVERVIEW OF THE STANDARDS

General overview

There are two different sets of regulatory systems on the international scene: the European/international system, and the North American system. These two systems differ considerably, so it is often very difficult for a product to comply with both of them. The gewiss multipolar connectors have, however, been tested and found to comply with both the European/international system and the North American one. This means they can be used worldwide, without problems.

European and international Standards

EN 61984 is the reference Standard in Europe. It implements and replaces the old DIN VDE 0627 which for years was the reference for this type of product. This document is standardised for the purpose of the European "Low Voltage" directive (Directive 73/23/EEC), and its fulfilment allows the product to be labelled EC. Compliance with this Standard is attained via a series of particularly complex tests which analyse the various mechanical, physical and electrical characteristics.

Mechanical tests

The purpose of the mechanical tests is to analyse the ability of the connectors to resist the stress levels they may be subjected to during normal operation, such as incorrect connection attempts, ineffective closing of earth connections, impacts and falls, excessive traction of the contacts. The tests envisaged by the Standard are as follows:

TYPE OF TEST	REFERENCE STANDARD
Marking indelibility:	EN 60068-2-70
The product marking must be indelible and easy to read.	The product marking is rubbed with a shape 1 piston, applying a force of 5N for a total number of 10 cycles.
Polarisation method:	EN 60512-7
The multipolar connectors must be polarised in such a way as to prevent any improper connection of the connectable parts (e.g. energising the earthing contact).	An attempt is made to incorrectly insert a male connector in a female connector in all possible positions, applying a force of 20N.
Earthing regulations:	EN 61984
The earthing contact must be the first to close and the last to open.	An attempt is made to insert a male connector in a female connector. Using a lightbulb, it is seen that the earthing contact is the first to close and the last to open, while all the other contacts are connected in parallel.
Terminals:	EN 60352-2
Connector terminals must comply with the relative applicable regulations, and safely retain the conductors.	For terminals to be crimped.
	EN 60999
	For screw-on terminals.
Impact resistance:	IEC 60512-8
After undergoing the programme of mechanical tests, a connector must not show any damage that could compromise safety.	A force equal to three times the specified insertion force (coupling) for one contact or the specified insertion force for one contact plus 50N (whichever of the two values is lower) is applied.
Resistenza meccanica all'urto:	IEC 60512-5
Un connettore non deve presentare danni tali da pregiudicare la sicurezza dopo l'esposizione alle sollecitazioni meccaniche secondo il programma di prova.	The sample is subjected to 8 cycles of falls from a height of 750mm. After each fall, the sample is turned 45° so that by the end of each cycle, every corner has been struck.

LIFESPAN TESTS

The lifespan tests simulate the normal operation of the connector during its normal working life. The tests are carried out with or without current, depending on whether the connectors are declared suitable for coupling/uncoupling while connected to the mains.

For connectors without breaking capacity, the following test is carried out:

TYPE OF TEST	REFERENCE STANDARD
Mechanical operations:	IEC 60512-5
The sample is subjected to a number of connections and disconnections equal to the number declared by the manufacturer.	The sample is subjected to a number of no-load connections and disconnections equal to the number declared by the manufacturer.

HEAT TESTS

The heat test analyses the ability of the connector to operate without its temperature exceeding the heat limits for the materials used:

Heating:	EN 60512-5-1
The sample must not reach dangerous temperatures when its own rated current passes through it.	The sample's own rated current is passed through it, until it reaches thermal conditions.

CLIMATIC TESTS

The climatic tests simulate the different conditions that the connectors could be subjected to, such as extremes of cold or heat, or highly polluted environments such as in industry.

Cold:	EN 60512-11-10
The sample must work correctly at the minimum declared operating temperature.	The sample is left in a cabin for 2 hours at the minimum operating temperature declared by the manufacturer.
Dry heat:	EN 60512-11-9
The sample must work correctly at the maximum declared operating temperature.	The sample is left in a cabin for 7 days at the maximum operating temperature declared by the manufacturer.
Corrosion in a gas mixture flow:	EN 60512-11-7
The metal parts must be made in such a way that corrosion does not compromise safety regarding the electrical and mechanical characteristics.	The sample is exposed to a mixture of H ₂ S for a period of 4 days.
Dielectric rigidity:	EN 61984
A connector must withstand the specified test voltage.	An 8/20-shaped test voltage is applied between the contacts, and between the contacts and the earth connection.

DEGREE OF PROTECTION

The tests for the degree of protection should demonstrate that device shells are able to offer protection against solid bodies or water (first and second figure of the IP rating).

Degree of protection:	EN 60529
The sample must guarantee the IP degree of protection declared by the manufacturer.	The sample is tested according to the declared degree of protection.

North American Standards

The GEWISS multipolar connectors also comply with American Standard UL 1977 and Canadian Standard CSA C22.2 No. 182.1. These two Standards are very similar and only differ as regards the allowable maximum temperature following the heating test. They call for the following test cycle:

Temperature test:	UL 1977 / CSA C22.2 No.182.3
The sample must not reach dangerous temperatures when its own rated current passes through it.	The sample's own rated current is passed through it, until it reaches thermal conditions.
Dielectric voltage withstand test:	UL 1977 / CSA C22.2 No.182.1
A connector must withstand the specified test voltage.	For 1 minute, an industrial frequency voltage (equal to 1000V plus double the rated voltage of the device) is applied.
Mould stress relief test:	UL 1977 / CSA C22.2 No.182.1
The sample must work correctly at the maximum declared operating temperature.	The sample is left in a cabin for 7 hours at the maximum operating temperature declared by the manufacturer.
Conductor secureness test:	UL 1977 / CSA C22.2 No.182.1
The terminals must hold the conductors safely and securely.	The sample is connected to the maximum and minimum section connectors, then subjected to a traction force.

GW CONNECT MULTIPOLAR CONNECTORS

General characteristics

The multipolar connectors of the GW Connect range have been designed to guarantee safe electrical connection in hostile environments such as industrial installations, automation, robotics, on-board machinery, control equipment, electric and electronic departments, and in chemical and petrochemical plants.

INSERTS

All the components are made of UL 94 V0 - GWT 960° self-extinguishing technopolymer, normally used in environments with temperatures from -40° to +125°C, colour Grey RAL 9002, with contact position numbering on both front and back (printed or applied with a laser device) to comply with EN 60068-2-70 Standard.

Various types of connection are available: screw-type, screwed with terminal block insert, the type to be crimped, and spring-type. The contacts are made of silver-plated or gilded copper alloy (10A - 80A), to guarantee better performance and easier connection/disconnection of the plug component. They can be used with alternating or direct current, and have a protection with earthing contact. The component fixing screws are made of nickel-plated steel; they are of the unlosable type, with anti-slip elastic washer and both slotted and cross head. All the components have a mechanical lifespan equivalent to (or greater than) 500 coupling cycles; remember that the connectors must never be coupled or uncoupled while connected to the mains. The screws and wire covers are made of stainless steel.

The inserts are designed for use with both alternating and direct current, facilitating all those connections requiring isolation of the power, command and signalling circuits. They have the following characteristics:

- protection with earthing contact;
- polarised for correct coupling;
- interchangeability of the male and female inserts in both fixed and mobile housings;
- unlosable screws;
- can be used with both fixed and mobile housings, or in applications on panels and racks.

HOUSINGS

The metal housings - both fixed and mobile - are made of die-cast aluminium alloy heat-painted with epoxy polyester powders (nickel-plated for the EMC versions), colour Grey RAL 7037. The housings made of insulating material for 21x21 inserts are in self-extinguishing technopolymer, colour Grey RAL 9002. The safety and stability of the coupling between the various housings is guaranteed by a closure system (single or double), with monobloc galvanised steel or stainless steel levers acting on the stainless steel pins, or in 100% plastic for the technopolymer housings.

The sealing gaskets are age-proof and offer maximum resistance to external chemical agents. All the housings - both metal and technopolymer - are available with either M or PG thread, and have:

- innovative design;
- standard 830V applications, hostile environments, and EMC;
- IP65 degree of protection (EN 60529);
- electrical earthing connection;
- notable mechanical and vibration resistance, guaranteed by the lever-operated closure system;
- metal covers with spring and closure system.

ACCESSORIES

The connection has a wide range of accessories to ensure protection and impermeability: cable glands in metal or thermoplastic material, IP65 and IP68, coupling devices, hexagonal nuts, wideners and reducers, coding pins to facilitate coupling, sealing gaskets and tools for crimping the contacts.

MULTIPOLAR CONNECTORS

SURFACE-MOUNTING BOXES IN DIE-CAST ALUMINIUM

The GW Connect range consists of seven different sizes of connection and junction boxes made of die-cast aluminium alloy. Suitable for every application, they are particularly recommended in industrial environments and on machinery. For particular applications is necessary contact GEWISS Service Technical Assistance.

The boxes have smooth walls and are equipped with a cover fixed with unlosable stainless steel screws with double slotted head; the sealing gasket is in EPDM foam rubber. The boxes can be surface-mounted from both the inside and outside; in particular, the external fixing operations (using brackets) do not interfere with the cover.

The earth terminal (for protection against indirect contact) is on both the back-mounting plate and the cover.

The outside of the box is covered with epoxy-polyester paint to ensure the maximum resistance with perfect design integration.

There are also unpainted versions and ATEX versions (directive 94/9/EC).

In the ATEX versions, the earth terminal is on the outside. Cable gland perforation tables are included with the dimension tables.

All the sizes have the appropriate internal pre-arrangement for the assembly of both the DIN rail and the perforated back-mounting plate in galvanised sheet steel (available as an accessory), to guarantee the utmost flexibility when fixing the terminals and other devices.

Technical data and compliance with standards

Reference Standards: IEC 60670; EN 60670-1; EN 60670-22; CEI EN 60670-1; CEI EN 60670-22; IEC 62208; EN 62208; CEI EN 62208	Shells for devices for fixed electrical installations, for domestic and similar uses
Degree of protection:	see indications below
Protection against indirect contact:	earthing via pre-arrangement of suitable terminals (external for the ATEX version)
Material:	painted/unpainted aluminium alloy
Impact resistance:	see indications below

Note: unpainted boxes of GW Connect range are not protected against oxidation. When removing protective packaging please pay attention to the storage in humid environments.

Technical data

Painted version	Unpainted version	ATEX version	Dimensions	IP rating	IK rating
GW 76 261	GW 76 281	GW 76 291	91x91x54	66	IK08
GW 76 262	GW 76 282	GW 76 292	128x103x57	66	IK08
GW 76 263	GW 76 283	GW 76 293	155x130x58	66	IK08
GW 76 264	GW 76 284	GW 76 294	178x156x75	66	IK08
GW 76 265	GW 76 285	GW 76 295	239x202x85	66	IK08
GW 76 266	GW 76 286	GW 76 296	294x244x114	66	IK08
GW 76 267	GW 76 287	GW 76 297	392x298x149	66	IK09

BEHAVIOUR WITH CHEMICAL AND CORROSIVE AGENTS									
	Water	Sea air	Acids	Bases	Ketones	Alcohols	Silicon oil	Oils/Greases	Petrol
Painted/ATEX versions	Resistant	Limited resistance	Limited resistance	Limited resistance	Resistant	Resistant	Resistant	Resistant	Resistant
Unpainted versions	Resistant	Not resistant	Not resistant	Not resistant	Resistant	Resistant	Resistant	Resistant	Resistant

MULTIPOLAR CONNECTORS

Dimension tables

JUNCTION BOXES IN DIE-CAST ALUMINIUM

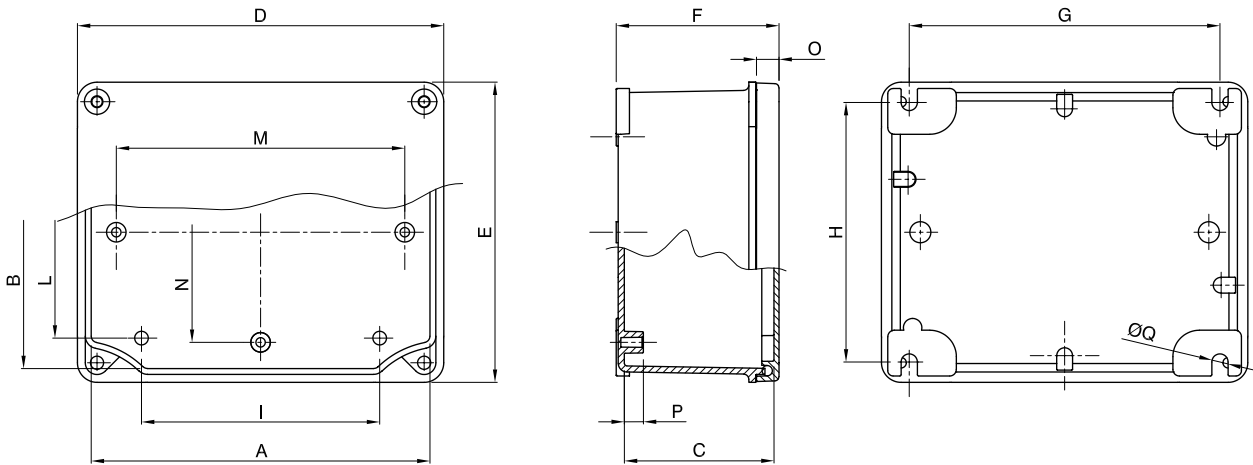

Code	A	B	C	D	E	F	G	H	I	L	M	N	O	P	Q
GW 76 261 / GW 76 281 / GW 76 291	91	91	54	101	101	58	80	88	52,5	42,5	-	-	8,3	7,5	6,1
GW 76 262 / GW 76 282 / GW 76 292	128	103	57	138,5	113,5	61,5	120	100	60	50	109	-	8,5	7,3	6,1
GW 76 263 / GW 76 283 / GW 76 293	155	130	58	165,5	140,5	63,5	144	125	104,5	102	135	110	8,6	7,2	6,1
GW 76 264 / GW 76 284 / GW 76 294	178	156	75	189	167	80	168	149	117	129,5	140	120	8,7	7,1	6,1
GW 76 265 / GW 76 285 / GW 76 295	239	202	85	252	215	91	226	196	178	164	208	168	9	8,7	8,7
GW 76 266 / GW 76 286 / GW 76 296	294	244	114	307	257	120,5	275	236	208	193,5	256	210	9,2	8,5	8,7
GW 76 267 / GW 76 287 / GW 76 297	392	298	150	406,5	312,5	157,1	367	283	290	237	320	230	15	8,5	8,7

BACK-MOUNTING PLATES

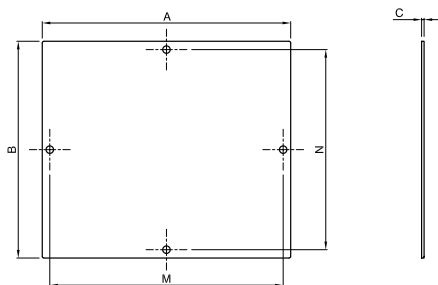

Code	A	B	C	M	N
GW 76 272	118,5	78,5	1,5	109	-
GW 76 273	144	119	1,5	135	110
GW 76 274	165	130	1,5	140	120
GW 76 275	219	179	1,5	208	168
GW 76 276	267	221	1,5	256	210
GW 76 277	345	260	2	320	230

GW CONNECT BOX DRILLING TABLE

HOLE DRILLING FOR ATEX BOX								
Junction box	Hole drilling on sides							Box perimeter Max. number of holes
	Long side				Short side			
Article	Ø mm	M	PG	No. of holes per long side	Ø mm	M	PG	No. of holes per short side
GW 76 291	16	16		1	16	16		1
	23		16		23		16	
GW 76 292	25	25		1	25	25		1
	29		21		29		21	
GW 76 293	25	25		2	25	25		1
	29		21		29		21	
GW 76 294	32	32		2	32	32		2
	37		29		37		29	
GW 76 295	40	40		2	40	40		2
	48		36		48		36	
GW 76 296	50	50		2	50	50		2
	54		42		54		42	
GW 76 297	50	50		3	50	50		2
	54		42		54		42	

MULTIPOLAR CONNECTORS

METAL BOXES

To complete the industrial range, there is also a selection of die-cast aluminium boxes for on-board installation, for the protection, command, connection and control of electric and electronic equipment.

REFERENCE STANDARDS

Most of the inserts of the GW Connect range comply with Standards IEC 61984 EN 61984 CEI EN 61984 «Connectors - Safety Prescription and Tests», VDE 0627 and UL 1977/CSA C22.2 182.3.

The EC mark is granted in accordance with the 73/23/EEC Low Voltage directive, and its subsequent modification 93/68/EEC.

The inserts and relative housings satisfy the EUROMAP (European Association of Plastic and Rubber Machinery Manufacturers) recommendations.

The products comply with European Directive 2002/95/EC regarding the restricted use of specific dangerous substances in electric and electronic equipment (RoHS).

The load characteristics, indicating admissible current capacity for the ambient temperature in which the connector is installed, are established in accordance with IEC 60512-5-2 EN 60512-5-2 CEI EN 60512-5-2.

Technical characteristics

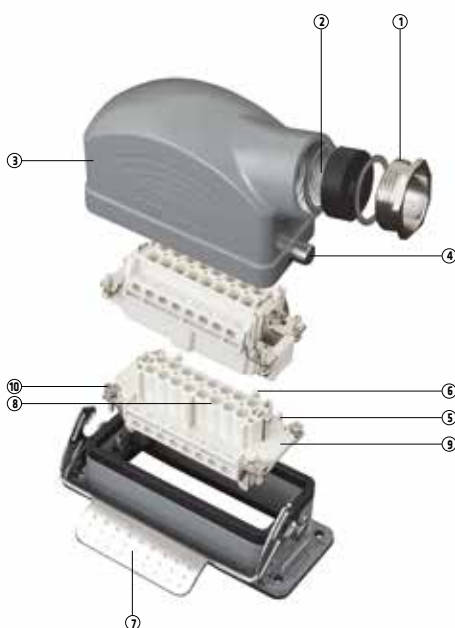

- 1 A large range of accessories to guarantee the insulation and stability of the connection.
- 2 Threaded cable passage hole, with different PG or metric pitch diameters (in accordance with EN 60423).
- 3 Robust housings in die-cast aluminium alloy or self-extinguishing thermoplastic (GW-A range).
- 4 Stainless steel pins that facilitate closure without suffering any surface damage.
- 5 Inserts in self-extinguishing thermoplastic reinforced with fibreglass, with operating temperature limits of -40°C and +125°C.
- 6 Polarised inserts profile with symmetrical guides to prevent incorrect coupling: mechanical lifespan equal to (or greater than) 500 coupling cycles.
- 7 Closure device with two possible solutions: simple (with one lever) or double (with two levers).
- 8 Silver-plated or gilded brass contacts connected to the conductors via unlosable screws.
- 9 EC mark (compliance with the directives 73/23/EEC and 93/68/EEC).
- 10 Unlosable fixing screws in stainless steel.

Overvoltages

The regulation regarding the overvoltage values sustainable by a component is based on the rated voltage of the component itself, and refers to the environment in which the device is installed. This determines the parameters to indicate an electrical device's resistance to overvoltage in the event of a power supply circuit malfunction, or extraordinary natural events such as lightning or a notable accumulation of electrostatic charge.

The "overvoltage" regulation influences the sizing of the components, in terms of air discharge distance values. The reference Standards envisage 4 categories of overvoltage for electric devices and components.

MULTIPOLAR CONNECTORS

Excerpt from DIN VDE 0110-1 and IEC 60664-1, paragraph 2.2.2.1.1

"Devices in **overvoltage category I**: Components for the connection of circuits protected by overvoltage level limiting devices.

Note: for instance, protected electronic circuits.

Devices in **overvoltage category II**: Electric equipment powered from a fixed source (mains supply).

Note: for instance, portable electric tools, household appliances, and electric equipment of a similar power level.

Devices and/or tools requiring special safety rules are included in category III.

Devices in overvoltage category III: equipment for fixed installations and all cases where device safety is subject to special regulations.

Note: for instance, one-way switches for fixed installations and industrial machinery permanently connected to the mains supply.

Devices in **overvoltage category IV**: Devices directly connected to the energy sources.

Note: for instance, electrical measurement tools, and primary overcurrent protection devices."

RATED IMPULSE WITHSTAND VOLTAGES (EN 61984)								
Rated voltage of the mains power supply (= the rated insulation voltage of the device)					Preferred values for rated impulse withstand voltage kV (1.2/50 μs)			
					Overvoltage categories			
					I	II	III	IV
Phase-earth voltage derived from the rated voltage of the AC mains power supply (r.m.s. value or DC voltage)	Voltage in AC (r.m.s. value)	Voltage in AC (r.m.s. value)	Voltage in AC (r.m.s. value, voltage in DC)	Voltage in AC (r.m.s. value, voltage in DC)	Levels with special protection	Level for electric devices (for domestic use and similar)	Level for power supply distribution systems	Input level
V	V	V	V	V				
100	66/115	66	60	-	0.5	0.8	1.5	2.5
150	120/208; 127/220	115; 120; 127	110; 120	220-110; 240-120	0.8	1.5	2.5	4
300	220/380; 230/400; 240/415; 260/440; 277/480.	220; 230; 240; 260; 277	220	440-220	1.5	2.5	4	6
600	347/600; 380/660; 400/690; 415/720; 480/830	347; 380; 400; 415; 440; 480; 500; 577; 600	480	960-480	2.5	4	6	8
1000		660; 690; 720; 830; 1000	1000	-	4	6	8	12

MULTIPOLAR CONNECTORS

Pollution rating

The sizing of the electrical components depends on the environmental use conditions. External pollution factors may alter the initial insulation properties of the contaminated surfaces. The pollution rating affects the sizing of the electrical components in terms of surface discharge distance.

The pollution rating defines the environmental conditions in which a device or component is installed without any additional protection. All the GW Connect industrial multipolar connectors are designed for use in areas of pollution rating 3.

Pollution rating 1:

In dry, clean environments with air conditioning - e.g. measurement laboratories and rooms housing computers.

Pollution rating 2:

In homes and offices, laboratories, light mechanics workshops, test rooms, shops and medical laboratories.

Pollution rating 3:

In industrial production environments, farms, unheated industrial warehouses, boiler rooms, rooms housing machine tools and industrial automation.

Pollution rating 4:

In outdoor work environments exposed to bad weather - e.g. components assembled on the roofs of railway vehicles, construction and industrial cranes, and construction site machinery.

Excerpt from VDE 0110-1 and IEC 60664-1, paragraph 2.5.1

“Pollution rating 3: conductive pollution, or dry non-conductive pollution made conductive by the presence of condensation.

Pollution rating 4: conductive pollution caused by conductive dust, rain or snow.”

Once compatibility with the basic rules has been established, the reference Standards for connectors allow them to be used in the pollution rating class immediately above the one for which they were designed. In such cases (envisaged by the reference regulations EN 61984), connectors designed for pollution rating class 2 can be used - with the necessary precautions - in areas of pollution rating class 3 (see the detailed restrictions and conditions in the excerpt below).

Excerpt from EN 61984, paragraph 6.19.2.2

“For a connector with at least an IP54 degree of protection, in accordance with IEC 60529, the insulating parts inside the housing may be sized for a lower pollution rating class. This also applies to coupled connectors whose closure is ensured by the connector housing, and which can only be decoupled for test and maintenance purposes.”

Typical applications of connectors designed for pollution rating class 2 used in areas with pollution rating class 3:

- connectors for electric motors, installed in an environment of pollution rating class 3, when the connector is envisaged and used for the quick replacement of the faulty motor;
- connectors to equip large machines which, for practical handling and installation reasons, need to be separated up into several parts. The use of housings with covers is recommended, to protect the connection during transportation.
- connectors positioned inside electric boards with at least an IP54 degree of protection. In these cases, it is possible to use the connector according to the parameters of pollution rating class 2, even without the aid of the protective housings.

An example of the electrical classification of a connector (EN 61984):

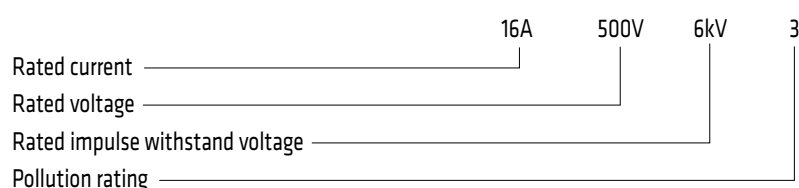

MULTIPOLAR CONNECTORS

AIR DISCHARGE DISTANCE

Minimum distance in the air between two conductive elements. The distance is determined by the maximum allowed peak voltage value.

SURFACE DISCHARGE DISTANCE

Minimum distance in the air between two conductive elements, measured on the surface of the insulating material: it is determined by the rated voltage, the pollution rating, and the dielectric characteristics of the insulating material.

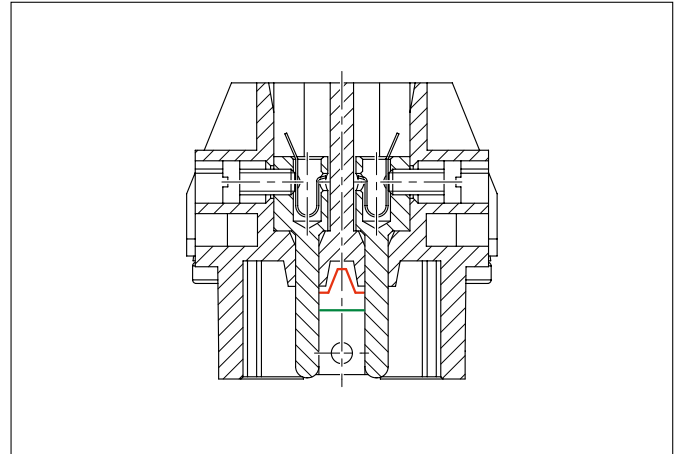

RATED VOLTAGE

Voltage value on which the working characteristics of the connector are based. This depends on the pollution rating (different rated voltage values can be identified for a single connector).

RATED IMPULSE WITHSTAND VOLTAGE

The impulse withstand voltage is determined on the basis of the overvoltage category and the rated voltage value. This level directly indicates the test voltage of the connector (wave shape 1.2/50 microseconds, according to IEC 60060-1).

RATED CURRENT

Current value (preferably determined at a temperature of 40°C) at which all the conductor contacts can be simultaneously charged, making the connection with cables with the maximum section permitted by the contact terminal, without exceeding the maximum material resistance temperature.

OVERVOLTAGES

Voltage peaks of an oscillating or non-oscillating nature, generally lasting just a few mS. Accidental overvoltages may be caused by intervention on one-way switches, or natural events such as lightning or electrostatic charges; they may also be intentionally generated for the functioning of the equipment.

TEST VOLTAGE AT A FREQUENCY LEVEL

Overvoltage at a frequency of 50/60Hz, applied for one minute to test the insulation of the dielectric material. See the test values according to EN 61984.

Impulse voltage kV (1.2/50 µs)	RMS voltage kV (50/60 Hz)
0.5	0.37
0.8	0.50
1.5	0.84
2.5	1.39
4	2.21
6	3.31
8	4.26
12	6.6

MULTIPOLAR CONNECTORS

INSULATING MATERIAL GROUP - CTI (COMPARATIVE TRACKING INDEX)

Value of electrical conductivity of the materials. It is essential for determining the surface discharge distance between two conductive elements. The CTI value is inversely proportional to the surface discharge distance: the higher the CTI, the lower the surface discharge distance. The CTI is used to classify the dielectric materials into insulation groups.

- I 600 ≤ CTI
- II 400 ≤ CTI < 600
- IIIa 175 ≤ CTI < 400
- IIIb 100 ≤ CTI < 175

LOAD DIAGRAMS (IEC 60512)

The degree of current capacity allowed in the connectors is variable: it diminishes with the growth of the number of poles and of the ambient temperature in which the connector is installed, and is determined by the thermal properties of the materials used for the contacts and insulating parts (including those of the conductor used).

It is obtained from the load characteristics constructed in accordance with Standard IEC 60512-3 for currents circulating in all the poles simultaneously.

The current limit characteristics show the current values which determine the attainment of the upper temperature limit of the materials. The choice of the permanent load to be applied to the contacts must be made within the permitted operation field indicated by these characteristics.

As the use of connectors at the limit of their characteristics is not advisable, the standard characteristic is declassified. The reduction of load currents to 80% defines the correction characteristic, in which sufficient account is taken of both the maximum contact resistance levels allowed and the inaccuracies in temperature measurements.

The correction characteristic represents the final current limit characteristic (load characteristic), as defined in Standard IEC 60512-3. It therefore takes into account the differences between the various connectors, and also temperature measurement errors.

All the load characteristics shown below already include the correction.

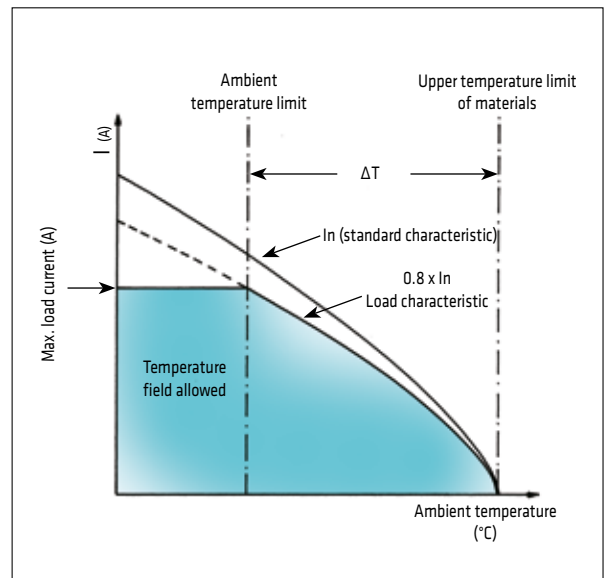

Maximum load current (A): value for which, at the ambient temperature (intersected on the load characteristic), the connector reaches the upper temperature limit of the material.

Upper temperature limit of the materials: value determined by the characteristics of the materials used. The sum of the ambient temperature plus the increase in temperature ΔT caused by the passage of the current must not exceed the upper temperature limit of the materials.

Ambient temperature limit: the ambient conditions must not exceed this value. The maximum load current may be known and determined, or directly obtained from the load characteristic.

Standard characteristic: the combination of the current and temperature values obtained from the laboratory tests and influenced by the characteristics of the connector (number of poles, construction form, thermal conductivity of the materials, etc.) and the section of the conductor used.

Load characteristic (current limit characteristic): obtained from the standard characteristic via the safety coefficient. In the real connector application context, not all the contacts are simultaneously loaded at full power. In these cases, it is possible to load certain contacts with current levels higher than those indicated in the load diagrams, without ever exceeding 20% of the total number of contacts.

ΔT (overtemperature): a temperature increased caused by a permanent current circulating in all the poles of a connector coupling. The difference between the upper limit temperature of the materials and the ambient temperature is shown on the current limit characteristic.

Peak currents: peak currents may occur in an electric circuit, caused for example by the start-up of electric motors or short-circuiting following faults. Events of this type, of relatively high intensity, provoke thermal stress in the contacts. It is difficult for the connector to quickly dissipate the heat generated, so, in the case of applications with frequent current peaks, special attention must be paid to the choice of connector configuration.

MULTIPOLAR CONNECTORS

DIAGRAM OF PEAK CURRENTS

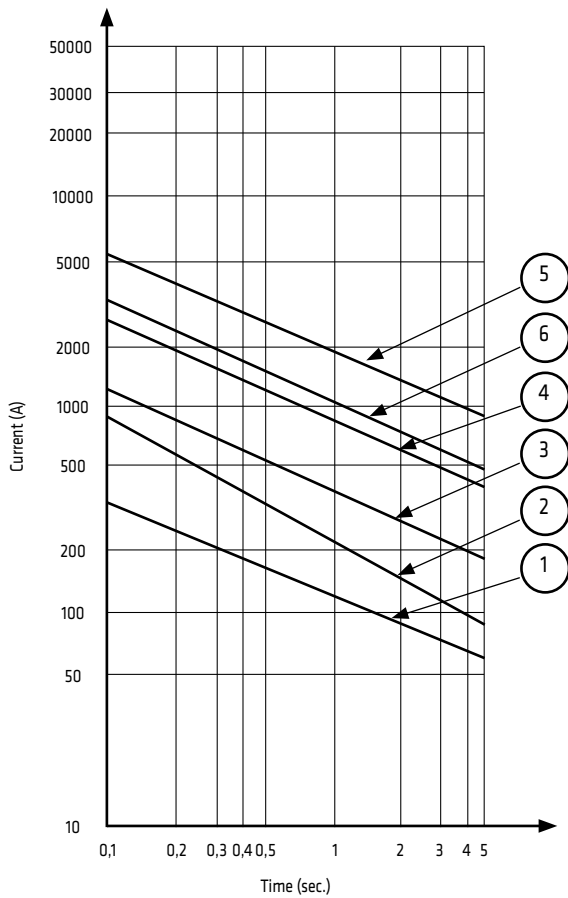

- | | | | |
|-----------|---------------------------------|-------|-------------|
| 1: | GW-D, GW-DD, GW-QD 12, GW-QD 17 | range | $I_N = 10A$ |
| 2: | GW-A 3A/4A | range | $I_N = 10A$ |
| 3: | GW-A (10A,16A) | range | $I_N = 16A$ |
| | GW-E, GW-EE, GW-ES | | |
| | GW-EHV, GW-ESHV | | |
| | GW-EAV, GW-Q 5/0 | | |
| | GW-QD 8/0 | | |
| 4: | GW-HSB | range | $I_N = 35A$ |
| 5: | GW-K | range | $I_N = 80A$ |
| 6: | GW-QD 4/2 | range | $I_N = 40A$ |

LOAD DIAGRAMS

GW-A range

SCREW CONNECTION 3P/4P+ $\frac{1}{2}$ 10A 230V/400V 4kV 3	
Component material:	self-extinguishing technopolymer UL 94 V0 - GWT 960°
Housing material:	technopolymer / aluminium alloy
Contact resistance:	$\leq 1 \text{ m}\Omega$
Insulation resistance:	$\geq 10 \text{ G}\Omega$
Temperature range:	-40°C +125°C
Electrical connection:	with screw for cables from 0.5 to 2.5mm ² (AWG 20-14)
Conductor stripping:	5mm
Tightening torque:	0.5 Nm
Type-approvals:	UL (USA), cUL (Canada)
Rated voltage (UL/cUL):	600V
Rated current (UL/cUL):	10A
Lifespan:	>=500 cycles

ELECTRICAL CHARACTERISTICS: LOAD DIAGRAMS

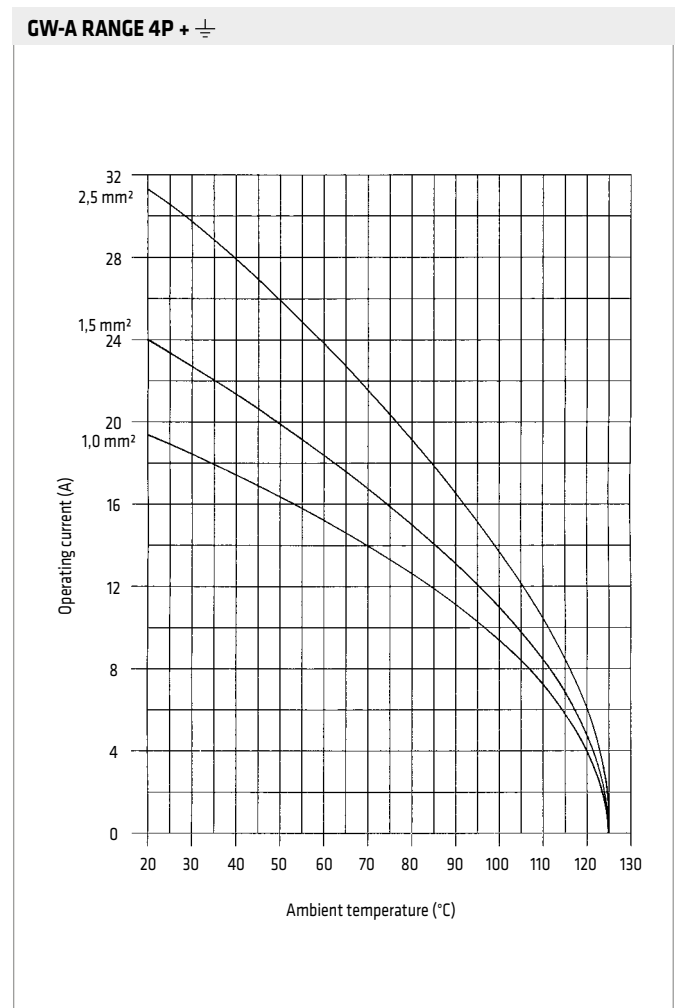
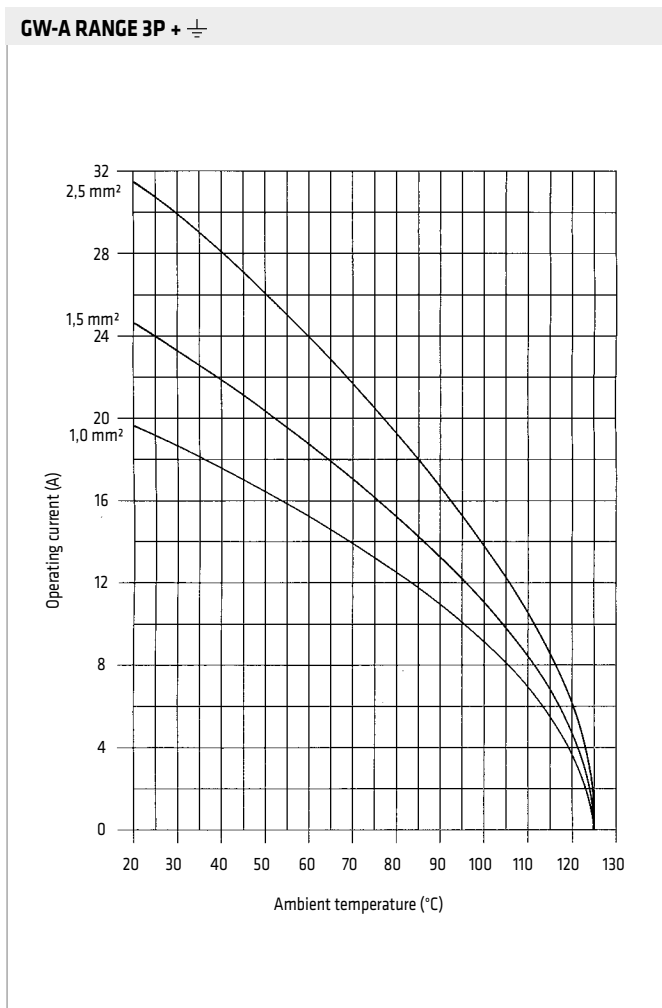

MULTIPOLAR CONNECTORS

SCREW AND CRIMPED CONNECTION 10P/16P/32P+ $\frac{1}{2}$ 10A 250V 4kV 3 (10A 230V/400V 4kV 2)	
Component material:	self-extinguishing technopolymer UL 94 V0 - GWT 960°
Housing material:	aluminium alloy
Contact resistance:	$\leq 1 \text{ m}\Omega$
Insulation resistance:	$\geq 10 \text{ G}\Omega$
Temperature range:	-40°C +125°C
Electrical connection:	screw: cables from 0.5 to 2.5mm ² (4mm ² without wire covers). AWG 20-14 (12) crimped: cables from 0.14 to 4mm ² , AWG 26-12
Conductor stripping:	screw: 7mm crimped: 7.5mm
Tightening torque:	0.5 Nm
Type-approvals:	UL (USA), cUL (Canada)
Rated voltage (UL/cUL):	600V
Rated current (UL/cUL):	10A
Lifespan:	≥ 500 cycles

ELECTRICAL CHARACTERISTICS: LOAD DIAGRAMS

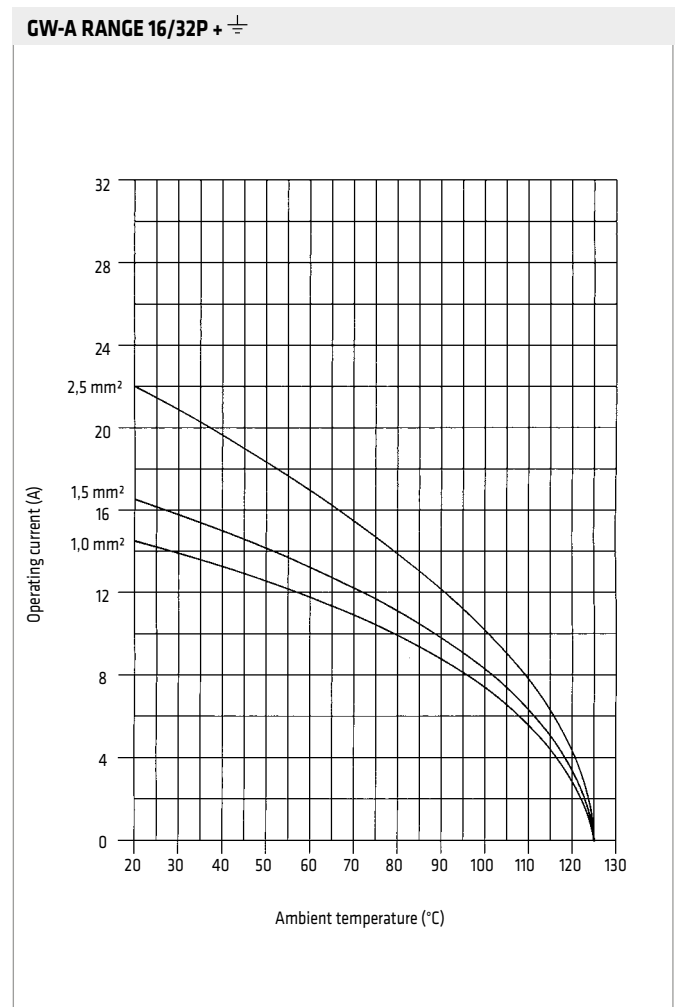
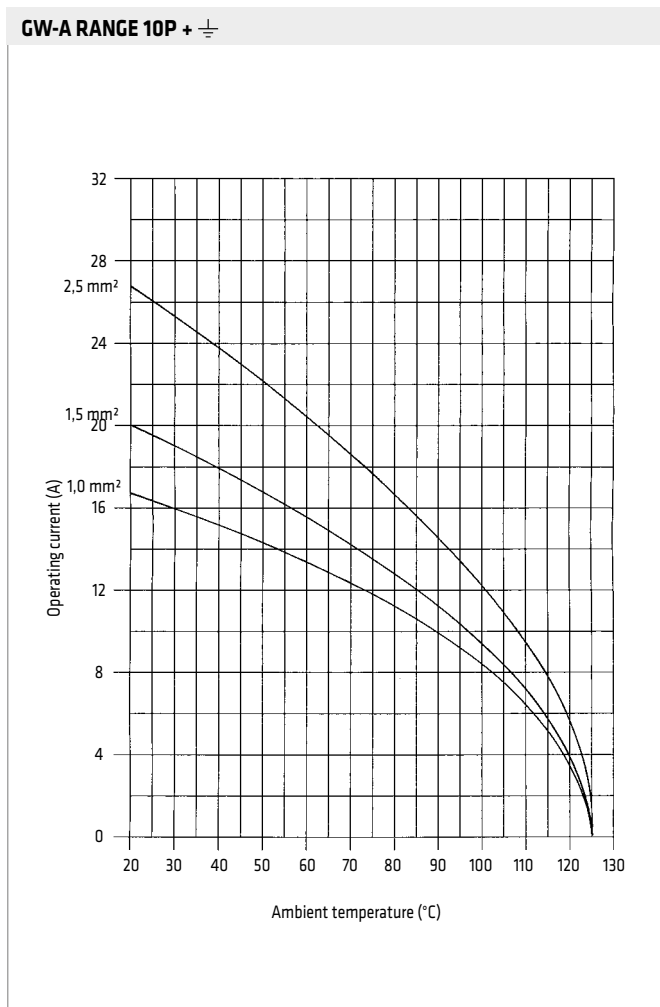

MULTIPOLAR CONNECTORS

GW-D range

Applications with higher voltage levels

By reducing the number of contacts and choosing the right pins, it is possible to apply voltage levels higher than those declared: this is thanks to the decrease in the number of connections, which implies an increase in the distance between the remaining ones. In compliance with Standard EN 61984, these contacts can reach up to 500V in pollution rating class 3.

FOR USES UP TO 500V IN POLLUTION RATING CLASS 3

GW-D 7 + $\frac{1}{2}$

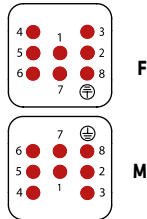

GW-D 3 + $\frac{1}{2}$

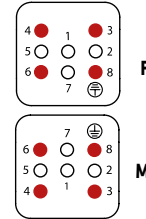

GW-D15 + $\frac{1}{2}$

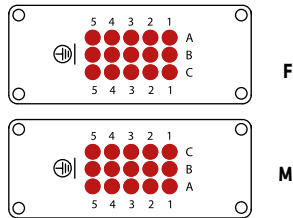

GW-D 7 + $\frac{1}{2}$

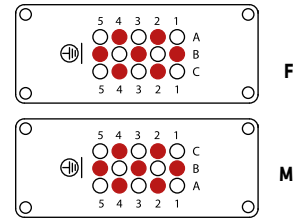

GW-D 25 + $\frac{1}{2}$

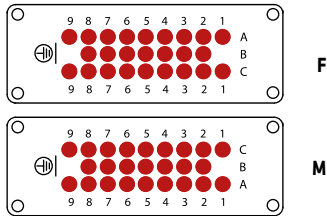

GW-D 11 + $\frac{1}{2}$

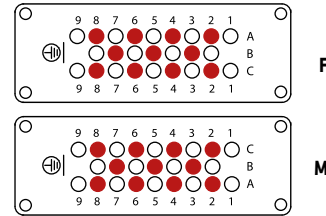

GW-D 40 + $\frac{1}{2}$

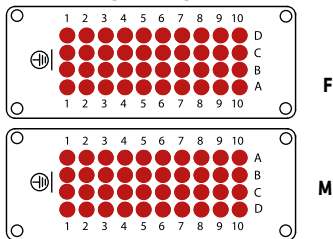

GW-D 20 + $\frac{1}{2}$

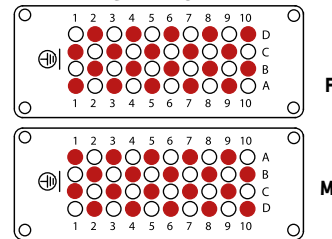

GW-D 64 + $\frac{1}{2}$

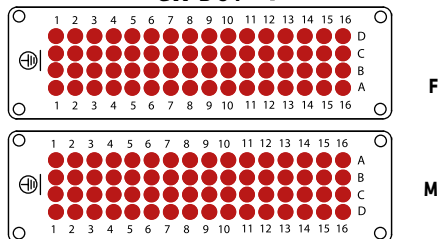

GW-D 32 + $\frac{1}{2}$

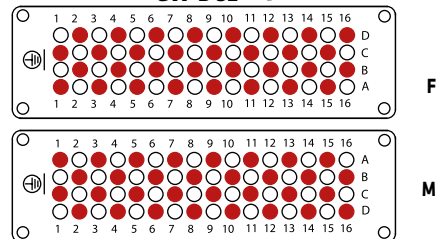

● Operating contact

○ Without contact

Side view of terminations

MULTIPOLAR CONNECTORS

CONNECTION TO BE CRIMPED 7P+ \pm 10A 250V 4kV 3 (10A 250V/400V 4kV 2)	
Component material:	self-extinguishing technopolymer UL 94 V0 - GWT 960°
Housing material:	aluminium alloy
Contact resistance:	$\leq 3 \text{ m}\Omega$
Insulation resistance:	$\geq 10 \text{ G}\Omega$
Temperature range:	-40°C +125°C
Electrical connection:	crimped: cables from 0.5 to 2.5mm ² , AWG 20-14
Conductor stripping:	crimped: 8mm
Type-approvals:	UL (USA), cUL (Canada)
Rated voltage (UL/cUL):	600V
Rated current (UL/cUL):	10A
Lifespan:	≥ 500 cycles

CONNECTION TO BE CRIMPED 8P 10A 50V 0.8kV 3	
Component material:	self-extinguishing technopolymer UL 94 V0 - GWT 960°
Housing material:	aluminium alloy
Contact resistance:	$\leq 3 \text{ m}\Omega$
Insulation resistance:	$\geq 10 \text{ G}\Omega$
Temperature range:	-40°C +125°C
Electrical connection:	crimped: cables from 0.14 to 2.5mm ² , AWG 26-14
Conductor stripping:	crimped: 8mm
Type-approvals:	UL (USA), cUL (Canada)
Rated voltage (UL/cUL):	50V
Rated current (UL/cUL):	10A
Lifespan:	≥ 500 cycles

ELECTRICAL CHARACTERISTICS: LOAD DIAGRAMS

GW-D RANGE 7P + \pm /8P

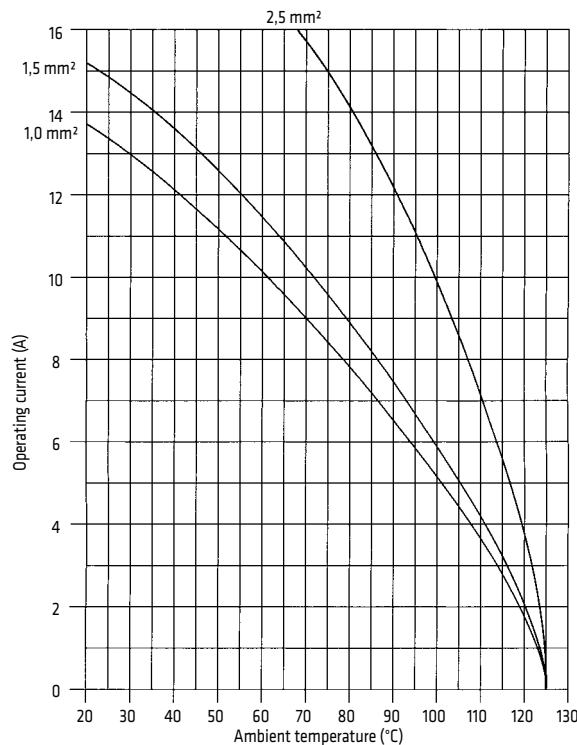

MULTIPOLAR CONNECTORS

CONNECTION TO BE CRIMPED 15/25/40/50/64/80/128P+ $\frac{1}{2}$ 10A 250V 4kV 3 (10A 250V/400V 4kV 2)

Component material:	self-extinguishing technopolymer UL 94 V0 - GWT 960°
Housing material:	aluminium alloy
Contact resistance:	<= 3 mOhm
Insulation resistance:	>= 10 GOhm
Temperature range:	-40°C +125°C
Electrical connection:	crimped: cables from 0.14 to 0.5mm ² , AWG 26-14
Conductor stripping:	crimped: 8mm
Type-approvals:	UL (USA), cUL (Canada)
Rated voltage (UL/cUL):	600V
Rated current (UL/cUL):	10A
Lifespan:	>=500 cycles

ELECTRICAL CHARACTERISTICS: LOAD DIAGRAMS

GW-D RANGE 15P + $\frac{1}{2}$

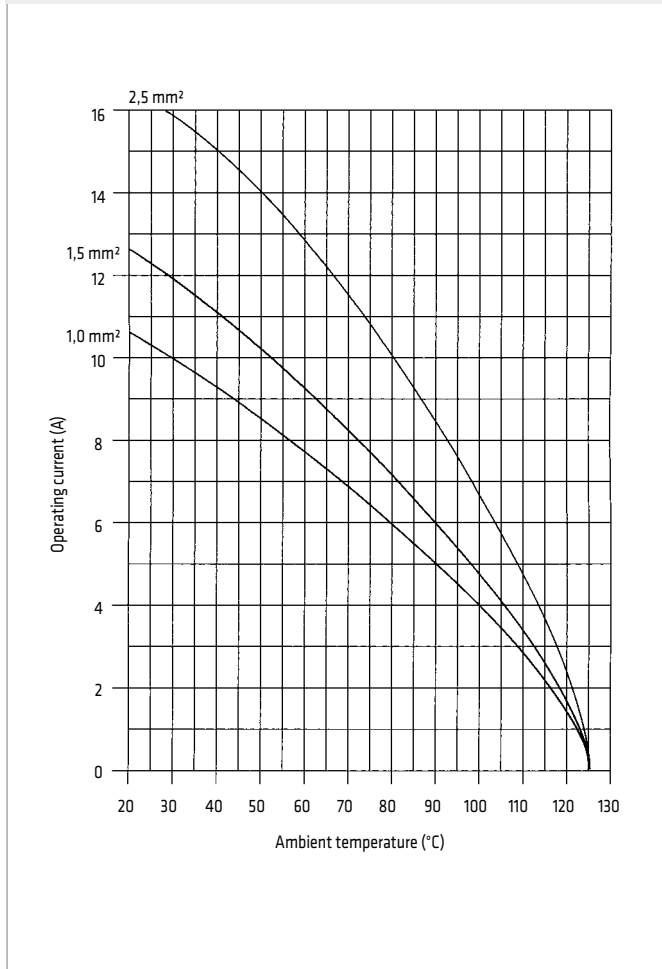

GW-D RANGE 25/50P + $\frac{1}{2}$

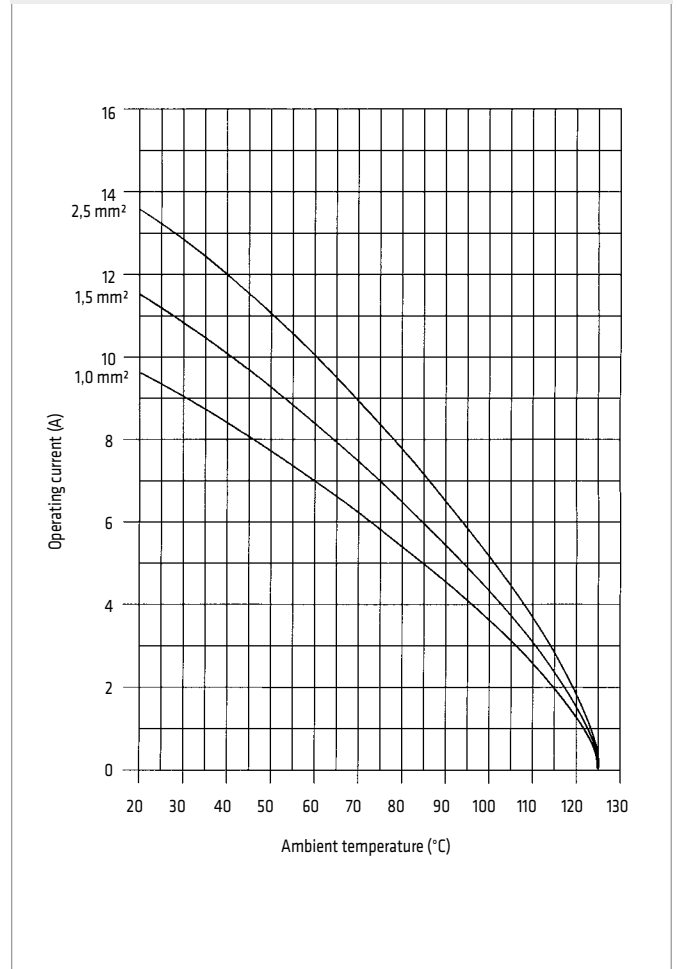

MULTIPOLAR CONNECTORS

GW-D RANGE 40/80P + $\frac{1}{2}$

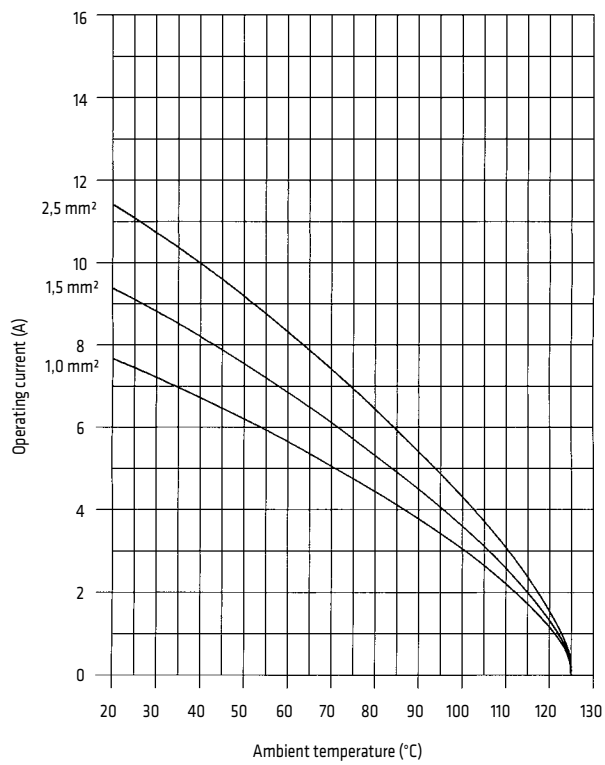

GW-D RANGE 64/128P + $\frac{1}{2}$

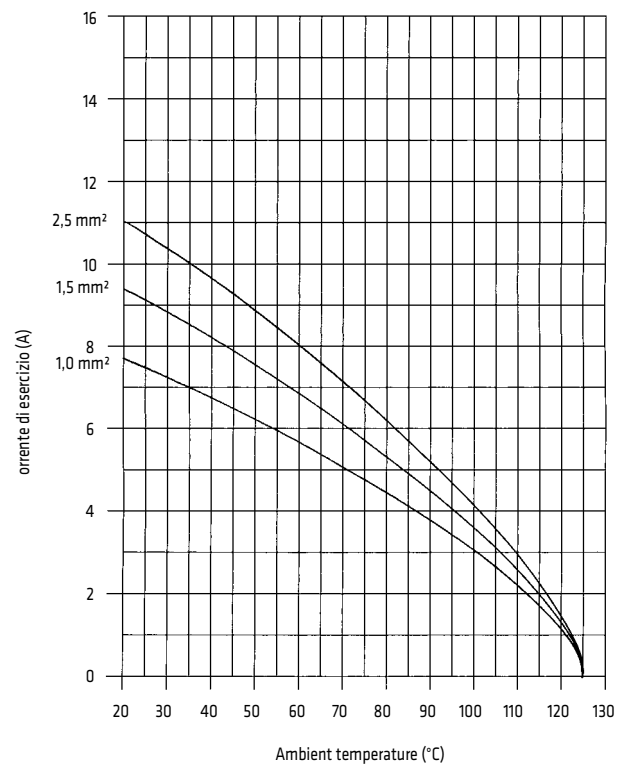

GW-DD range

Applications with higher voltage levels

FOR USES UP TO 250V IN POLLUTION RATING CLASS 3	FOR USES UP TO 400V IN POLLUTION RATING CLASS 3	FOR USES UP TO 500V IN POLLUTION RATING CLASS 3
<p>GW-DD 24 + $\frac{1}{2}$</p>	<p>GW-DD 12 + $\frac{1}{2}$</p>	<p>GW-DD 5 + $\frac{1}{2}$</p>
<p>GW-DD 42 + $\frac{1}{2}$</p>	<p>GW-DD 21 + $\frac{1}{2}$</p>	<p>GW-DD 11 + $\frac{1}{2}$</p>
<p>GW-DD 72 + $\frac{1}{2}$</p>	<p>GW-DD 34 + $\frac{1}{2}$</p>	<p>GW-DD 17 + $\frac{1}{2}$</p>
<p>GW-DD 108 + $\frac{1}{2}$</p>	<p>GW-DD 52 + $\frac{1}{2}$</p>	<p>GW-DD 26 + $\frac{1}{2}$</p>

- Operating contact
- Without contact

Side view of terminations

MULTIPOLAR CONNECTORS

CONNECTION TO BE CRIMPED 24/42/72/108/144/216P+ $\frac{1}{2}$ 10A 250V 4kV 3 (10A 250V/400V 4kV 2)	
Component material:	self-extinguishing technopolymer UL 94 V0 - GWT 960°
Housing material:	aluminium alloy
Contact resistance:	$\leq 3 \text{ m}\Omega$
Insulation resistance:	$\geq 10 \text{ G}\Omega$
Temperature range:	-40°C +125°C
Electrical connection:	crimped: cables from 0.14 to 0.25mm ² (AWG 26-14)
Conductor stripping:	crimped: 8mm
Type-approvals:	UL (USA), cUL (Canada)
Rated voltage (UL/cUL):	600V
Rated current (UL/cUL):	10A
Lifespan:	≥ 500 cycles

ELECTRICAL CHARACTERISTICS: LOAD DIAGRAMS

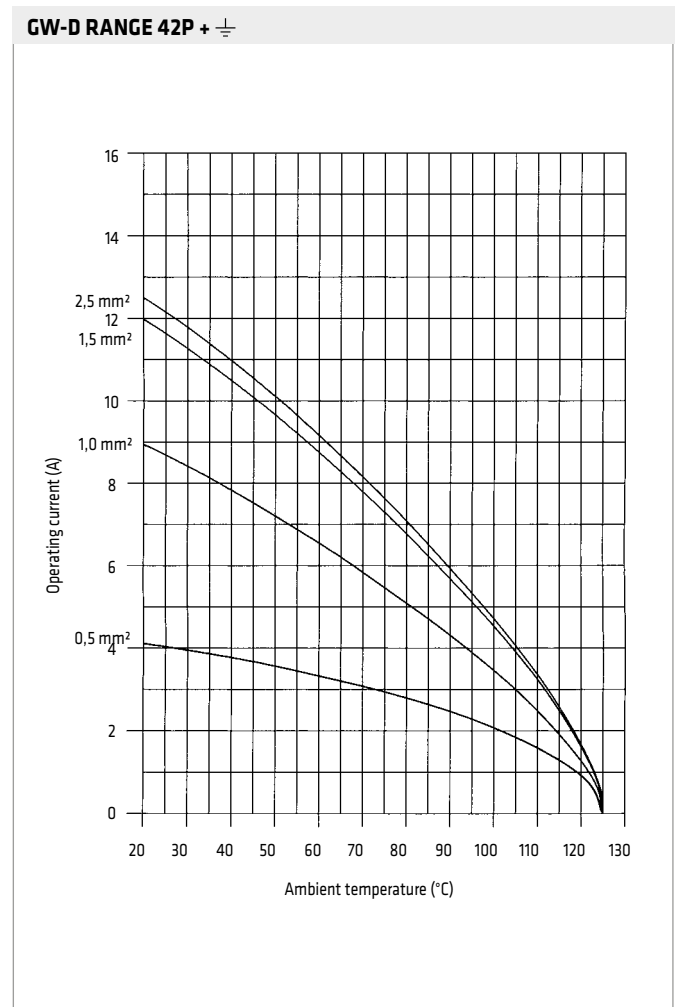
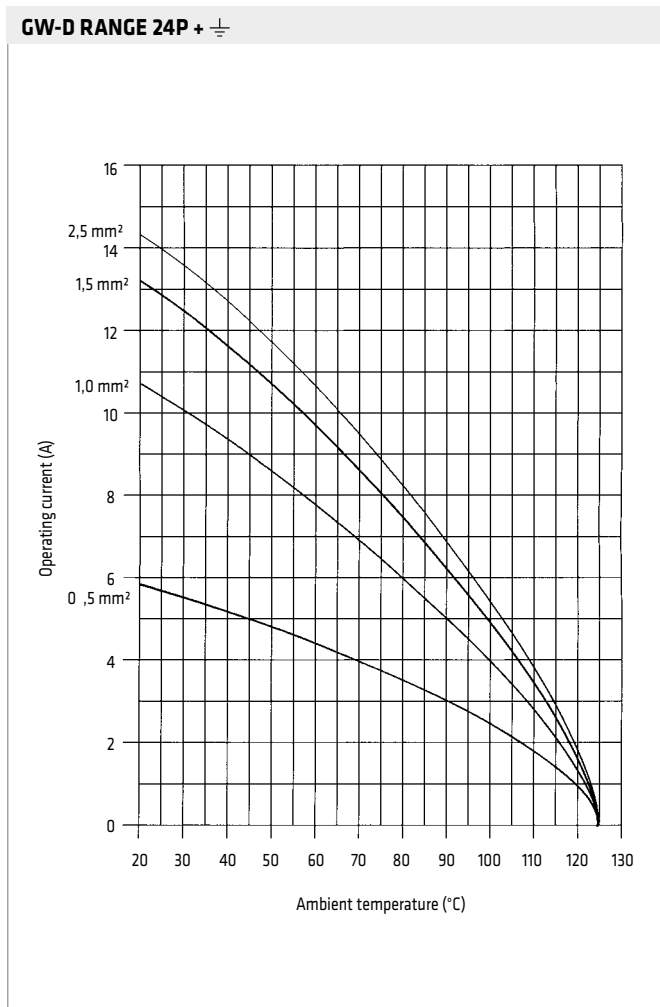

MULTIPOLAR CONNECTORS

GW-D RANGE 72/144P + $\frac{1}{2}$

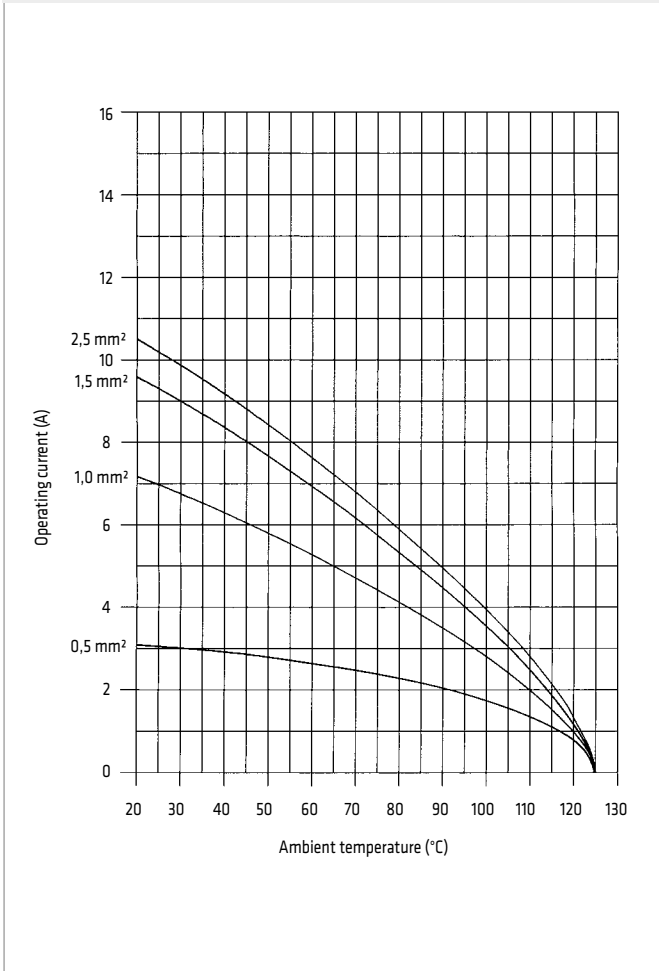

GW-D RANGE 108/216P + $\frac{1}{2}$

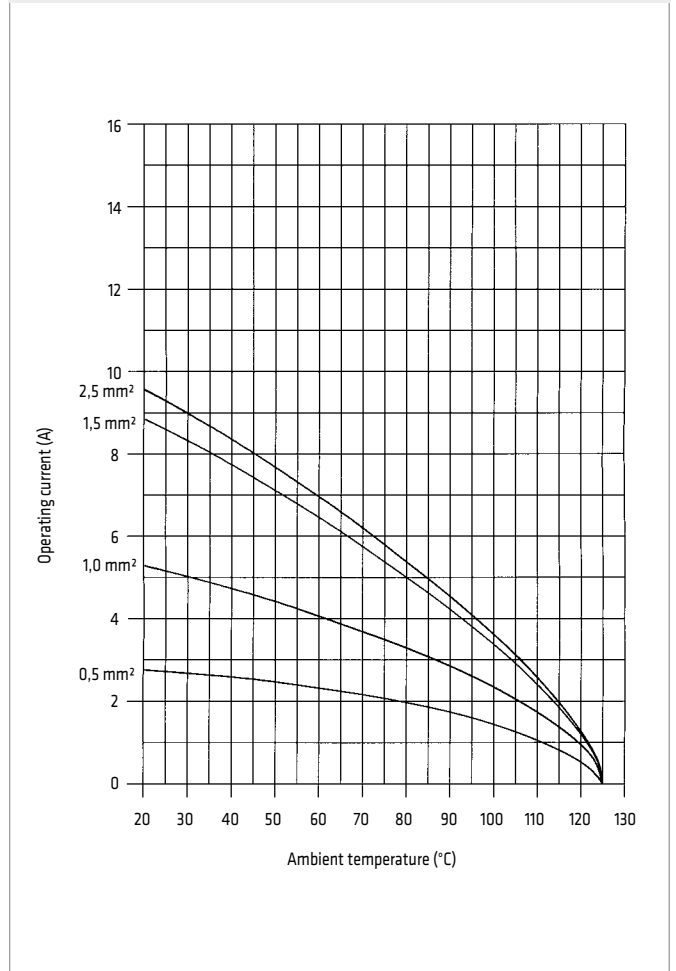

MULTIPOLAR CONNECTORS

GW-E range

SCREW AND CRIMPED CONNECTION 6/10/16/32/48P+ $\frac{1}{2}$ 16A 500V 4kV 3 (16A 400V/690V 4kV 2)	
Component material:	self-extinguishing technopolymer UL 94 V0 - GWT 960°
Housing material:	aluminium alloy
Contact resistance:	$\leq 1 \text{ m}\Omega$
Insulation resistance:	$\geq 10 \text{ G}\Omega$
Temperature range:	-40°C +125°C
Electrical connection:	screw: cables from 0.5 to 0.25mm ² (4mm ² without wire cover), AWG 20-14 (12) crimped: cables from 0.14 to 0.25mm ² , AWG 26-12
Conductor stripping:	screw: 7mm crimped: 7.5mm
Type-approvals:	UL (USA), cUL (Canada)
Rated voltage (UL/cUL):	600V
Rated current (UL/cUL):	16A
Lifespan:	≥ 500 cycles

Note: for the load diagrams, refer to the graphics of the GW-EAV range

MULTIPOLAR CONNECTORS

GW-EE RANGE

Applications with higher voltage levels

FOR USES UP TO 500V IN POLLUTION RATING CLASS 3	FOR USES UP TO 690V IN POLLUTION RATING CLASS 3	FOR USES UP TO 1000V IN POLLUTION RATING CLASS 3
<p>GW-EE 10 + $\frac{1}{2}$</p>	<p>GW-EE 4 + $\frac{1}{2}$</p>	<p>GW-EE 2 + $\frac{1}{2}$</p>
<p>GW-EE 18 + $\frac{1}{2}$</p>	<p>GW-EE 8 + $\frac{1}{2}$</p>	<p>GW-EE 4 + $\frac{1}{2}$</p>
<p>GW-EE 32 + $\frac{1}{2}$</p>	<p>GW-EE 14 + $\frac{1}{2}$</p>	<p>GW-EE 8 + $\frac{1}{2}$</p>
<p>GW-EE 46 + $\frac{1}{2}$</p>	<p>GW-EE 20 + $\frac{1}{2}$</p>	<p>GW-EE 12 + $\frac{1}{2}$</p>

- Operating contact
- Without contact

Side view of terminations

MULTIPOLAR CONNECTORS

SCREW AND CRIMPED CONNECTION 10/18/32/46/64/92P + $\frac{1}{2}$ 16A 500V 4kV 3 (16A 400V/690V 4kV 2)	
Component material:	self-extinguishing technopolymer UL 94 V0 - GWT 960°
Housing material:	aluminium alloy
Contact resistance:	$\leq 1 \text{ m}\Omega$
Insulation resistance:	$\geq 10 \text{ G}\Omega$
Temperature range:	-40°C +125°C
Electrical connection:	crimped: cables from 0.14 to 4.0mm ² , AWG 26-12
Conductor stripping:	crimped: 7.5mm
Lifespan:	≥ 500 cycles

ELECTRICAL CHARACTERISTICS: LOAD DIAGRAMS

GW-EE RANGE 10P + $\frac{1}{2}$

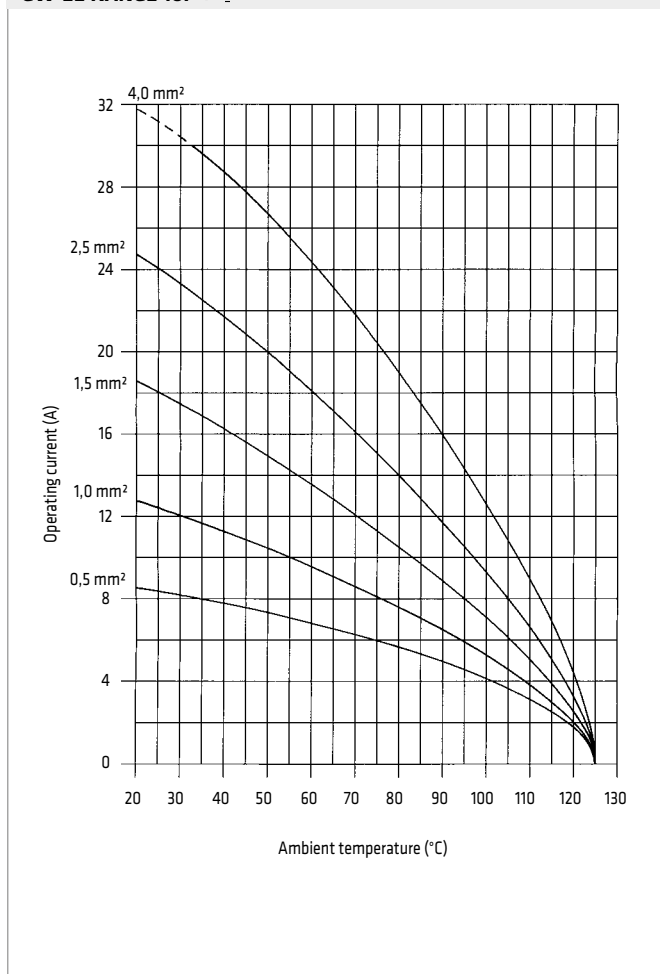

GW-EE RANGE 18P + $\frac{1}{2}$

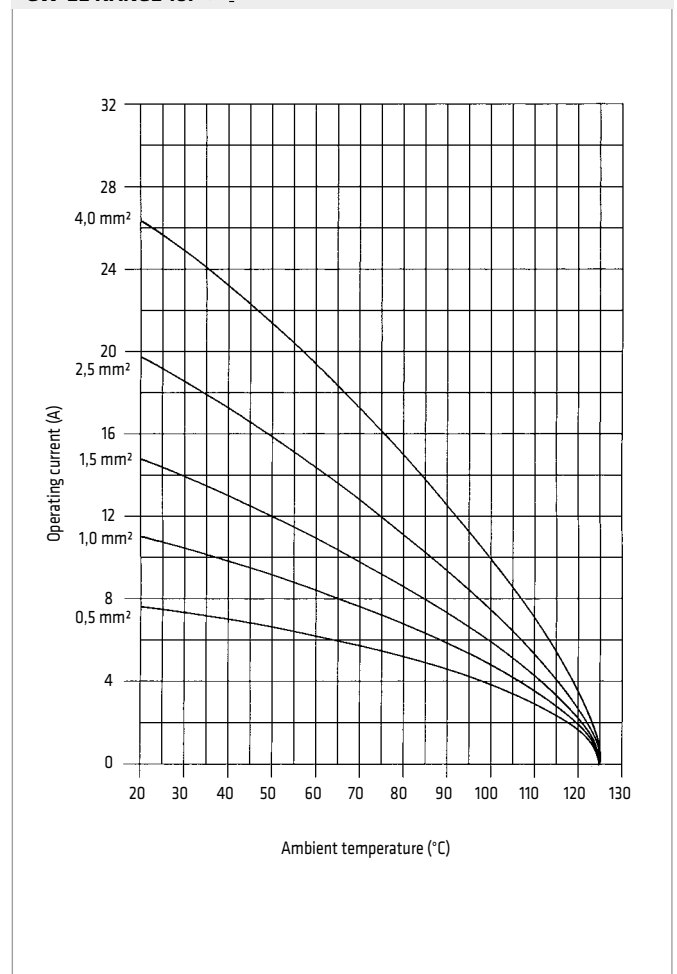

MULTIPOLAR CONNECTORS

GW-EE RANGE 32/64P + $\frac{1}{2}$

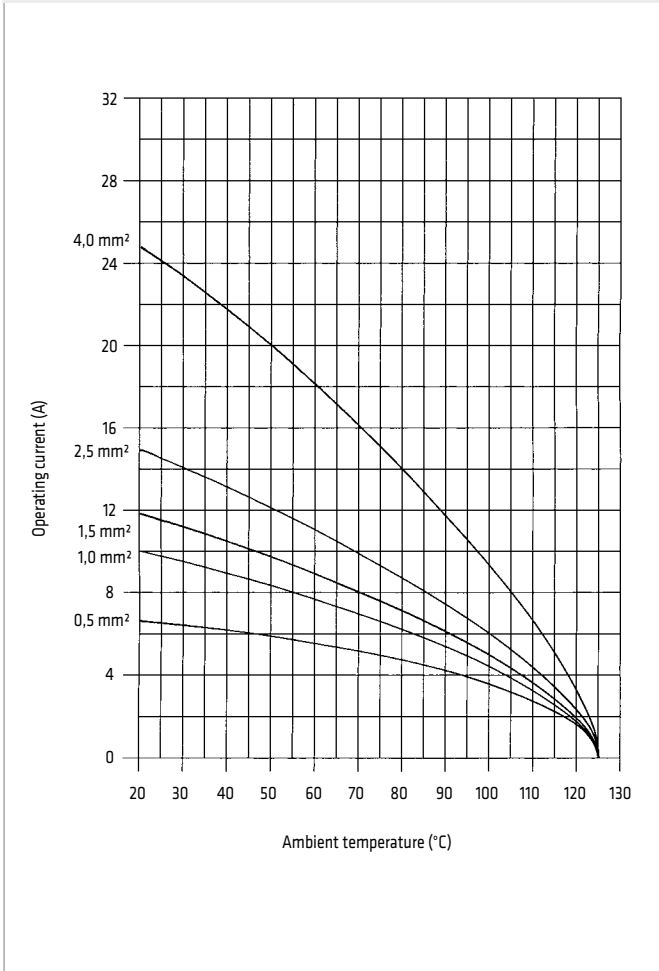

GW-EE RANGE 46/92P + $\frac{1}{2}$

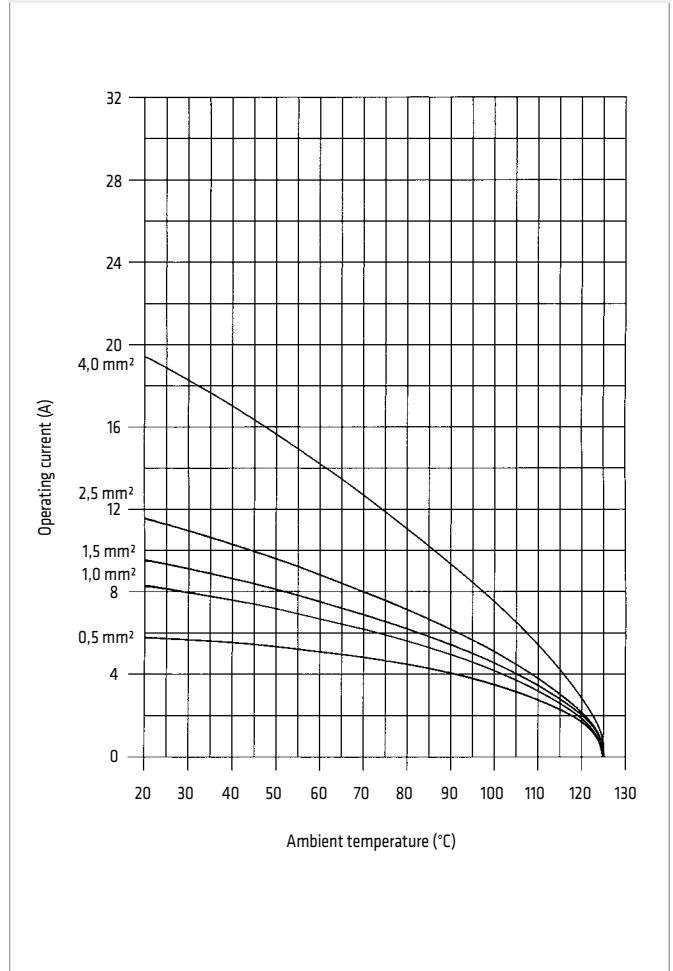

MULTIPOLAR CONNECTORS

GW-ES range

SPRING CONNECTION 6/10/16/24/32/48P + $\frac{1}{2}$ 16A 500V 6kV 3 (16A 400/690V 6kA 2)	
Component material:	self-extinguishing technopolymer UL 94 V0 - GWT 960°
Housing material:	aluminium alloy
Contact resistance:	$\leq 3 \text{ m}\Omega$
Insulation resistance:	$\geq 10 \text{ G}\Omega$
Temperature range:	-40°C +125°C
Electrical connection:	spring: cables from 0.5 to 2.5mm ² , AWG 20-14 (12)
Conductor stripping:	8mm
Type-approvals:	UL (USA), cUL (Canada)
Rated voltage (UL/cUL):	600V
Rated current (UL/cUL):	16A
Lifespan:	≥ 500 cycles

ELECTRICAL CHARACTERISTICS: LOAD DIAGRAMS

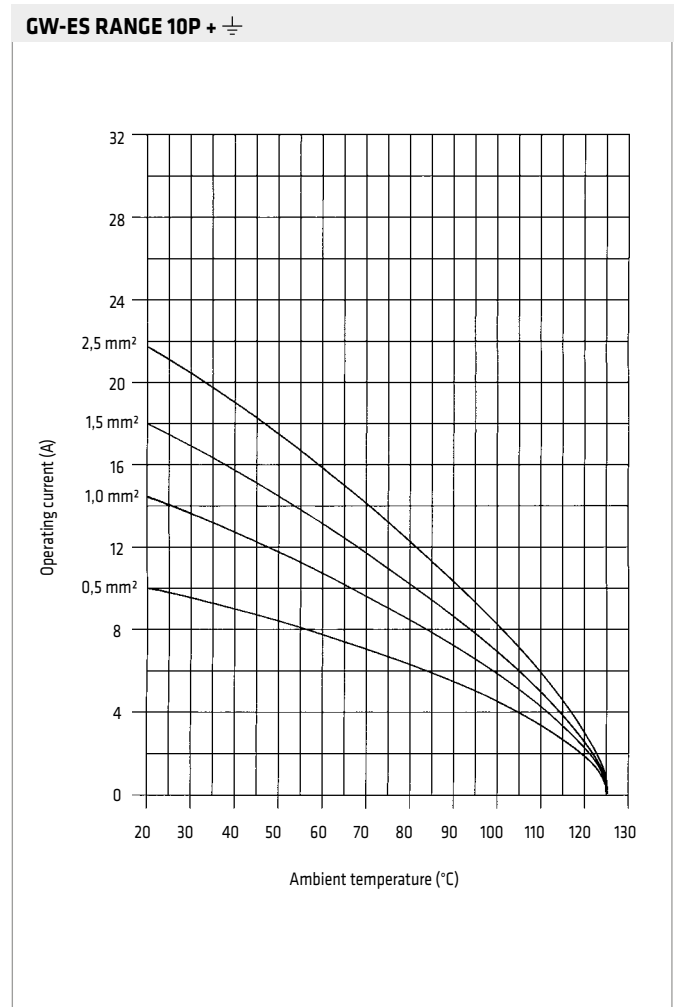
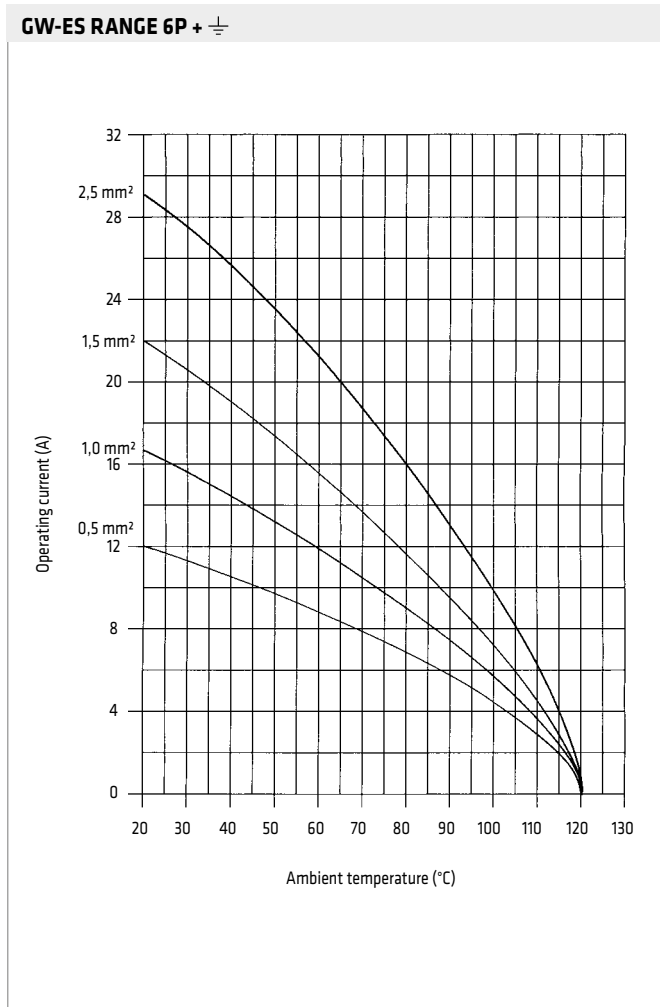

MULTIPOLAR CONNECTORS

GW-ES RANGE 16+32P + $\frac{1}{2}$

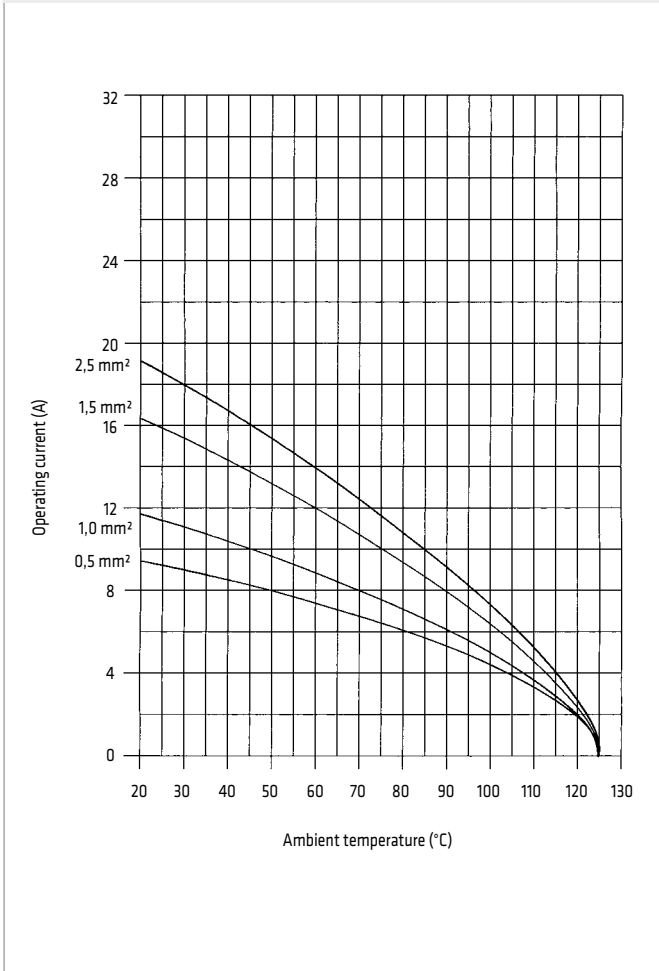

GW-ES RANGE 24+48P + $\frac{1}{2}$

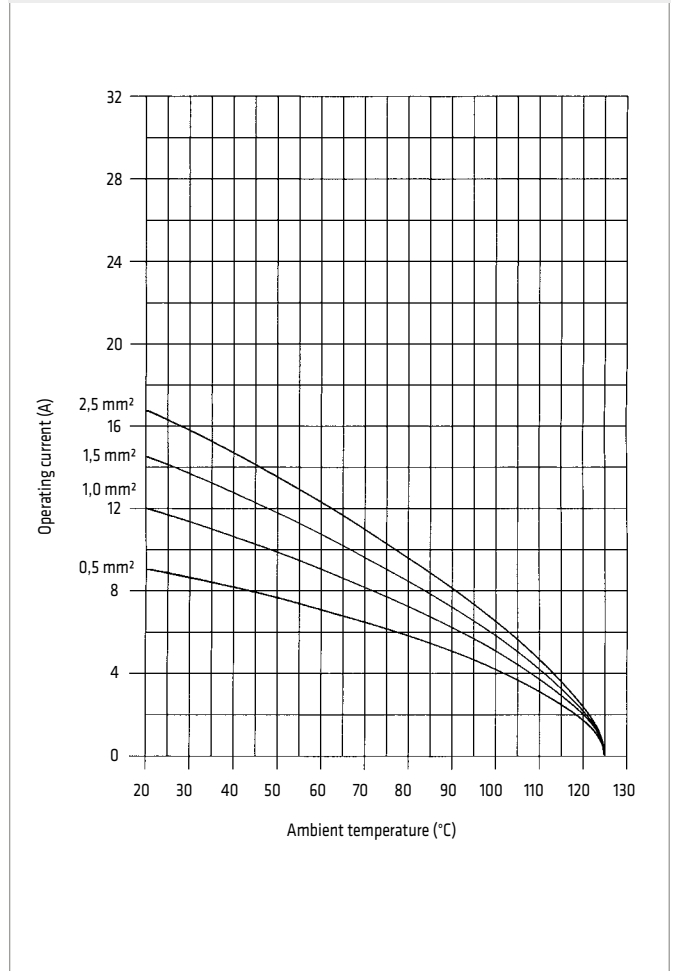

MULTIPOLAR CONNECTORS

GW-EAV range

The use of the multipolar connectors of the GW-EAV range is recommended for improved savings and safety when creating connections on the machine and in electric boards for command and control.

When assembling the board, it is necessary to use flush-mounting housings: this maintains the IP65 degree of protection (in accordance with EN 60529) for connectors assembled in a housing and then coupled.

The particular structure of the GW-EAV inserts, with all the conductor connection points on the same side, means easy wiring and a complete overall view of the work area.

The installation of the components on DIN rails inside the command boards is usually done to facilitate the division of the wiring into disconnectable parts. In this case, the degree of protection for coupled connectors is IP20.

SCREW TERMINAL BLOCK CONNECTION 6/10/16/24P+ $\frac{1}{2}$ 16A 500V 6kV 3 (16A 400V/690V 6kV 2)	
Component material:	self-extinguishing technopolymer UL 94 V0 - GWT 960°
Housing material:	aluminium alloy
Contact resistance:	≤ 2 mOhm
Insulation resistance:	≥ 10 GOhm
Temperature range:	-40°C +125°C
Electrical connection:	screw: cables from 0.2 to 2.5mm ² , AWG 20-14
Conductor stripping:	screw: 12mm
Lifespan:	≥ 500 cycles

ELECTRICAL CHARACTERISTICS: LOAD DIAGRAMS

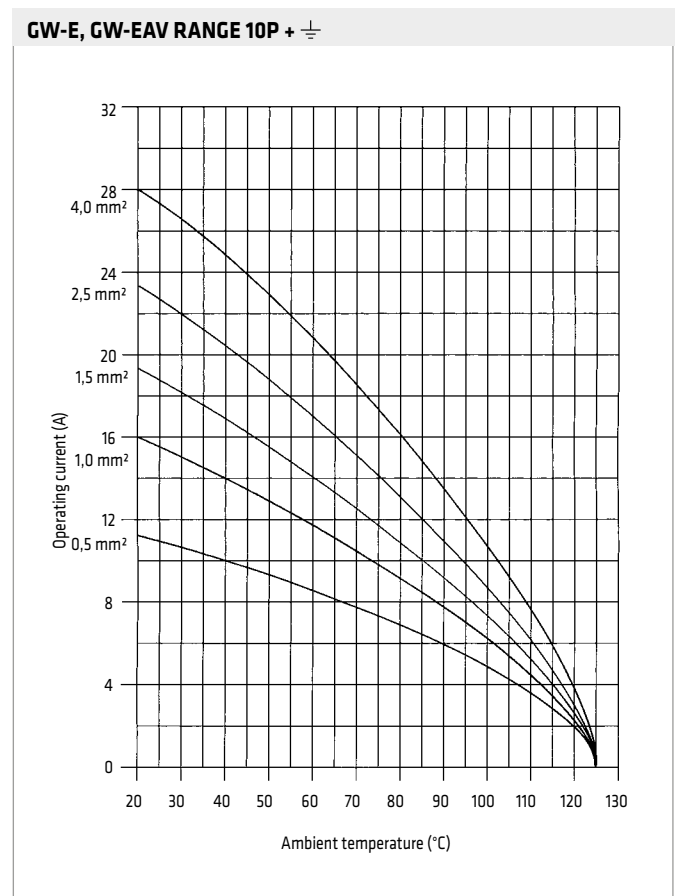
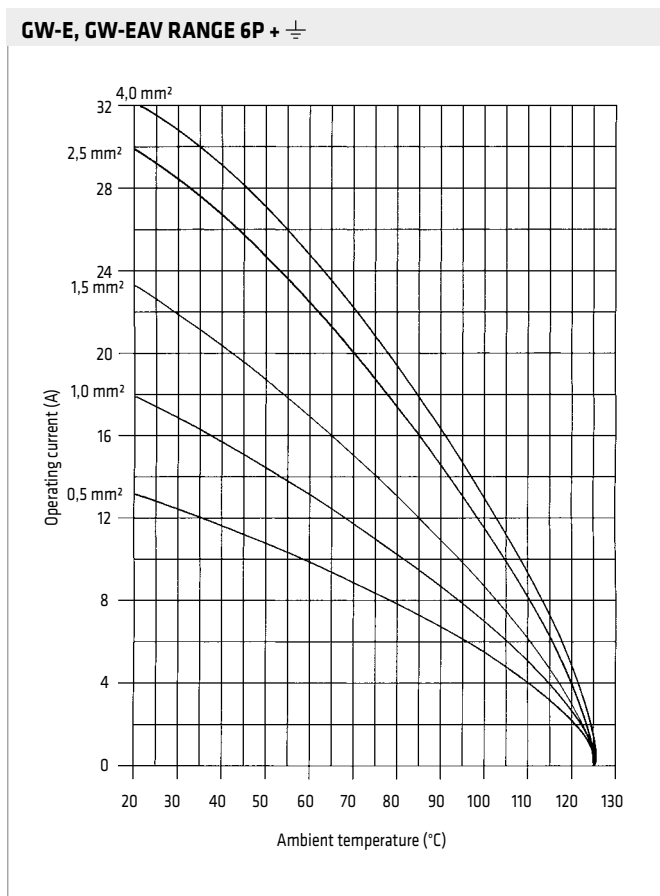

MULTIPOLAR CONNECTORS

GW-E, GW-EAV RANGE 16/32P + $\frac{1}{2}$

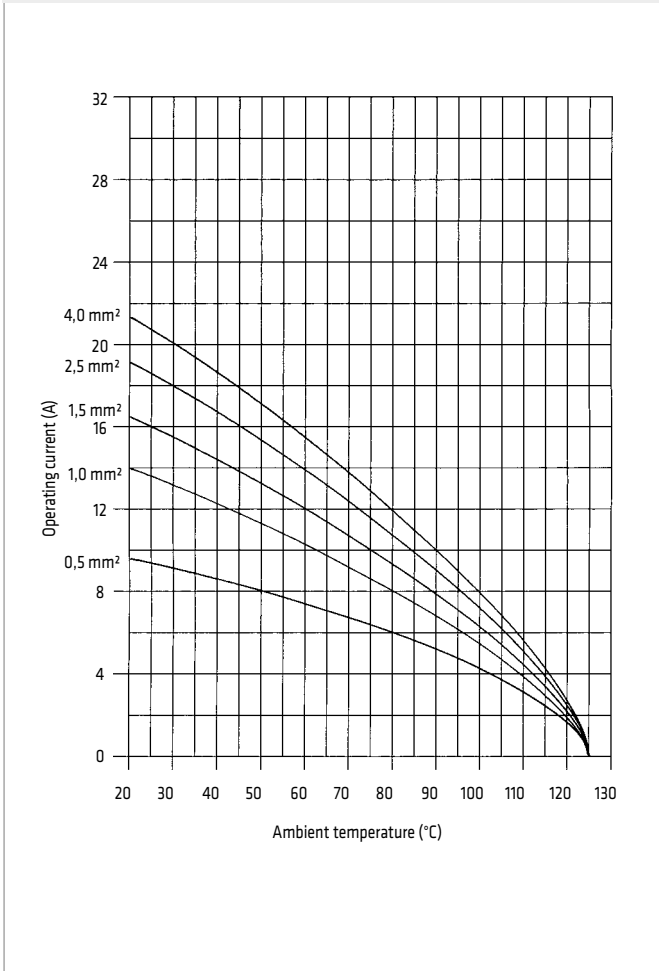

GW-E, GW-EAV RANGE 24/28P + $\frac{1}{2}$

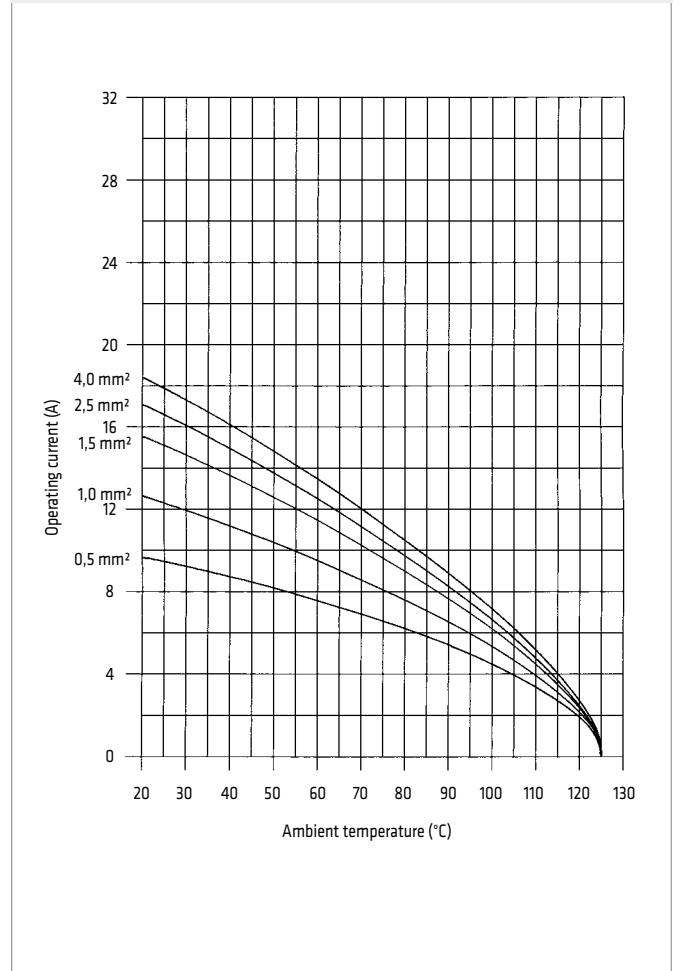

MULTIPOLAR CONNECTORS

GW-EHV range

For this type of insert, the use of the special housings for voltages up to 830V is recommended: they have additional insulating strips that guarantee the performance level.

SCREW AND CRIMPED CONNECTION 3,6,10,12,20P+ $\frac{1}{2}$ WITH 2/4 AUXILIARY CONTACTS 16A 830V 8kV 3 (16A 1000V 8kV 2; AUXILIARY CONTACTS 16A 500V 6kV 3) SCREW AND CRIMPED CONNECTION 16,32P+ $\frac{1}{2}$ WITH 2/4 AUXILIARY CONTACTS 16A 830V 6kV 3	
Component material:	self-extinguishing technopolymer UL 94 V0 - GWT 960°
Housing material:	aluminium alloy
Contact resistance:	<= 1 mOhm
Insulation resistance:	>= 10 GOhm
Temperature range:	-40°C +125°C
Electrical connection:	screw: cables from 0.5 to 2.5mm ² (4.0mm ² without wire cover), AWG 20-14 (12)
Tightening torque:	0.5 Nm
Conductor stripping:	7mm
Electrical connection:	crimped: cables from 0.14 to 4mm ² , AWG 26-12
Tightening torque:	0.5 Nm
Conductor stripping:	7.5mm
Type-approvals:	UL (USA), cUL (Canada)
Rated voltage (UL/cUL):	600V
Auxiliary contacts:	250V
Rated current (UL/cUL):	16A
Lifespan:	>=500 cycles

ELECTRICAL CHARACTERISTICS: LOAD DIAGRAMS

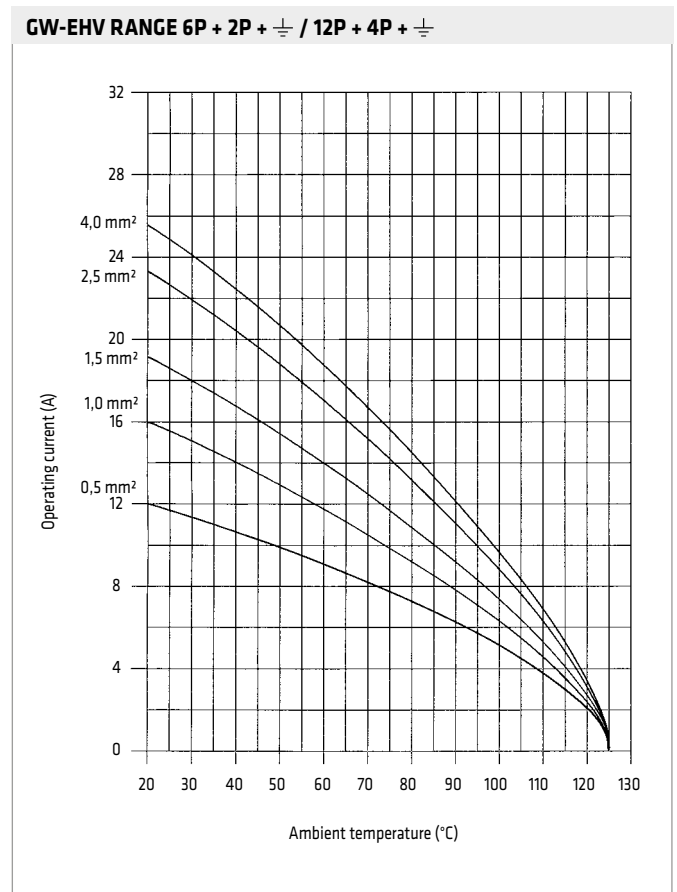
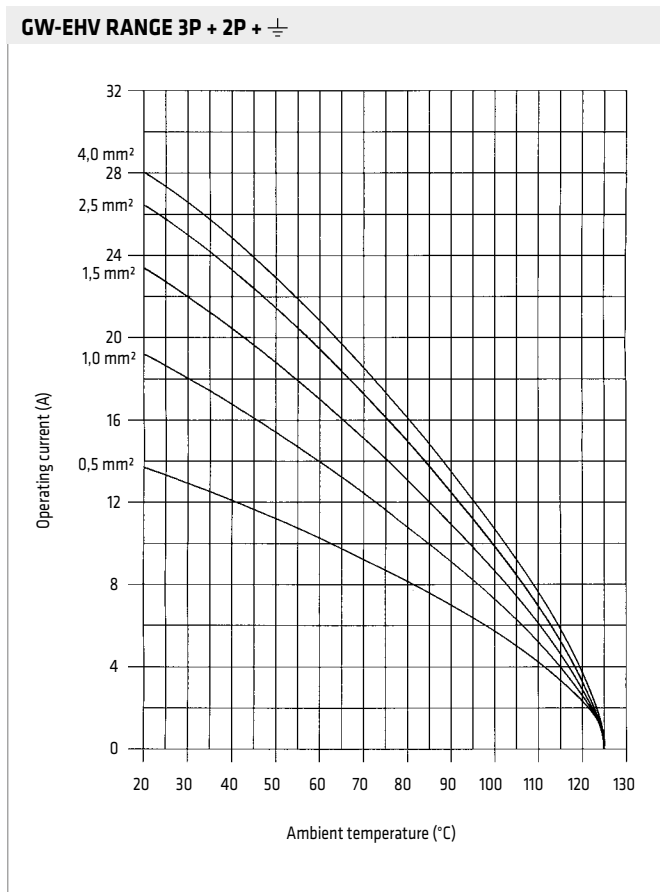

For technical information contact the Technical Assistance Service or visit gewiss.com

MULTIPOLAR CONNECTORS

GW-EHV RANGE 10P + 2P + $\frac{1}{2}$ / 20P + 4P + $\frac{1}{2}$

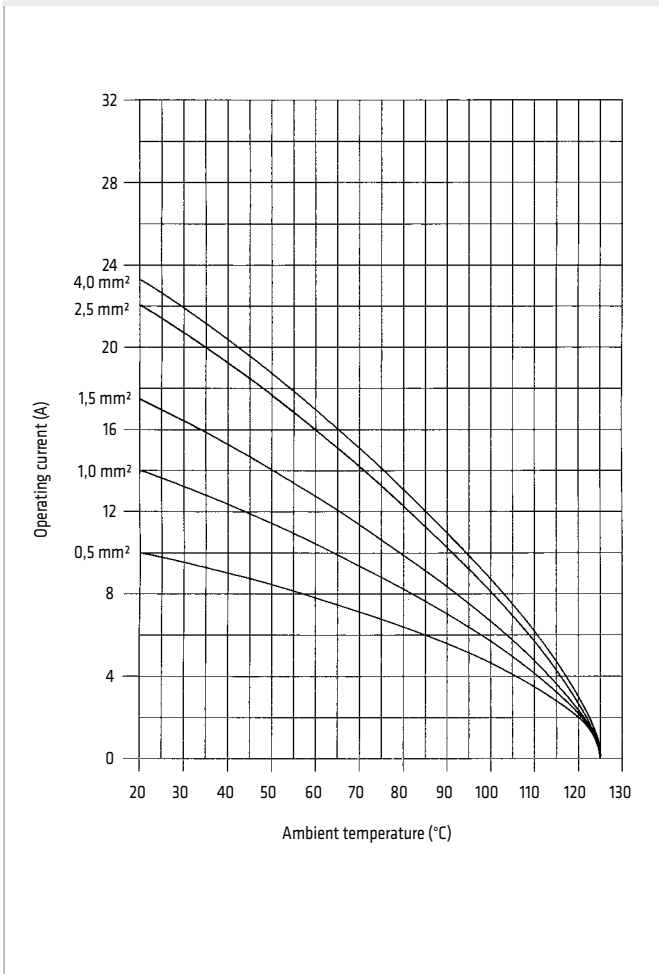

GW-EHV RANGE 16P + 2P + $\frac{1}{2}$ / 32P + 4P + $\frac{1}{2}$

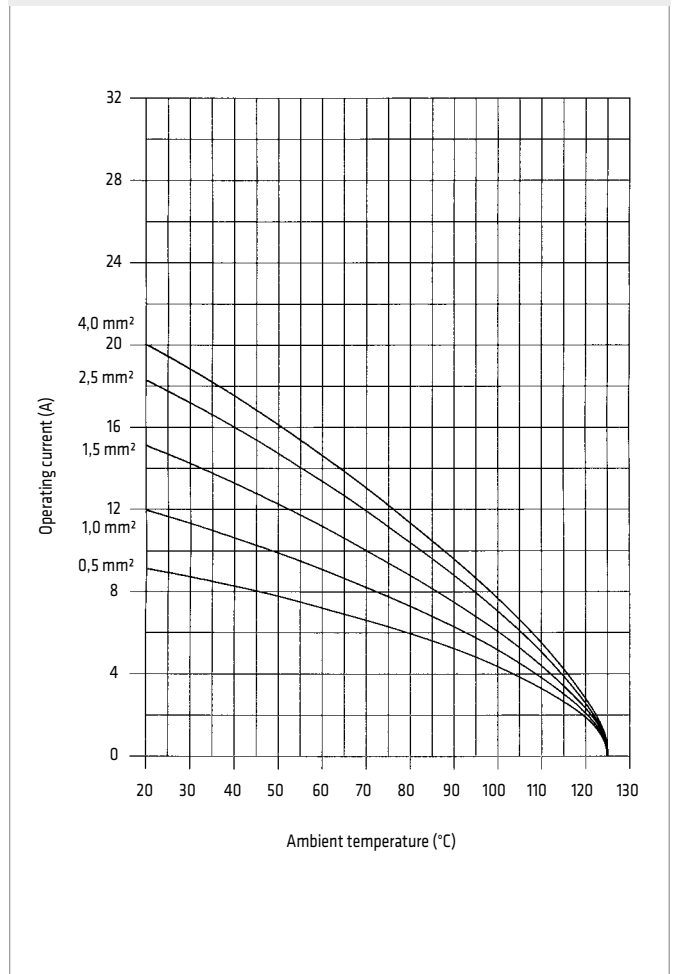

MULTIPOLAR CONNECTORS

GW-ESHV range

SPRING CONNECTION 3,6,10,12,20P+ $\frac{1}{2}$ WITH 2/4 AUXILIARY CONTACTS 16A 830V 8kV 3 (16A 1000V 8kV 2; AUXILIARY CONTACTS 16A 500V 6kV 3)	
Component material:	self-extinguishing technopolymer UL 94 V0 - GWT 960°
Housing material:	aluminium alloy
Contact resistance:	$\leq 3 \text{ m}\Omega$
Insulation resistance:	$\geq 10 \text{ G}\Omega$
Temperature range:	-40°C +125°C
Electrical connection:	cables from 0.14 to 2.5mm ² , AWG 26-14
Conductor stripping:	7mm
Type-approvals:	UL (USA), cUL (Canada)
Rated voltage (UL/cUL):	600V
Auxiliary contacts:	250V
Rated current (UL/cUL):	16A
Lifespan:	> 500 cycles

ELECTRICAL CHARACTERISTICS: LOAD DIAGRAMS

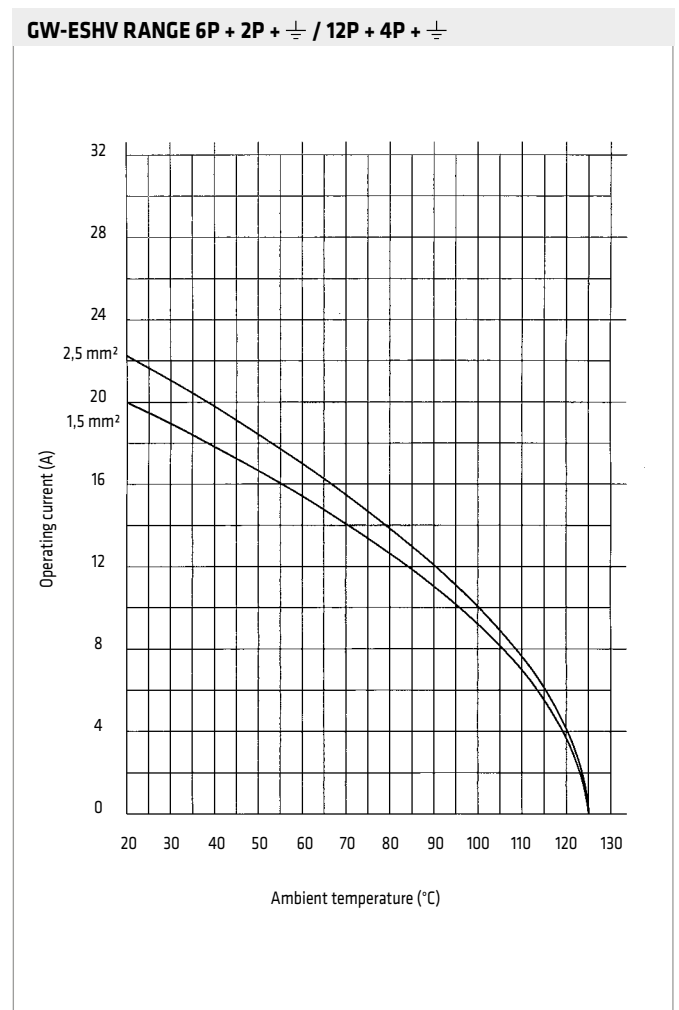
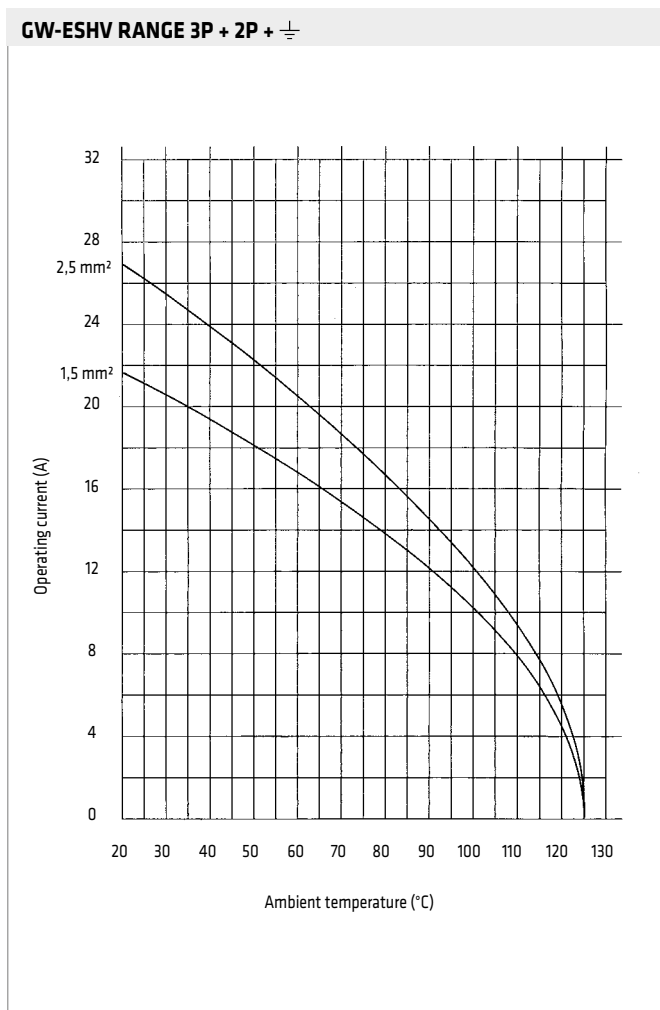

MULTIPOLAR CONNECTORS

GW-ESHV RANGE 10P + 2P + $\frac{1}{2}$ / 20P + 4P + $\frac{1}{2}$

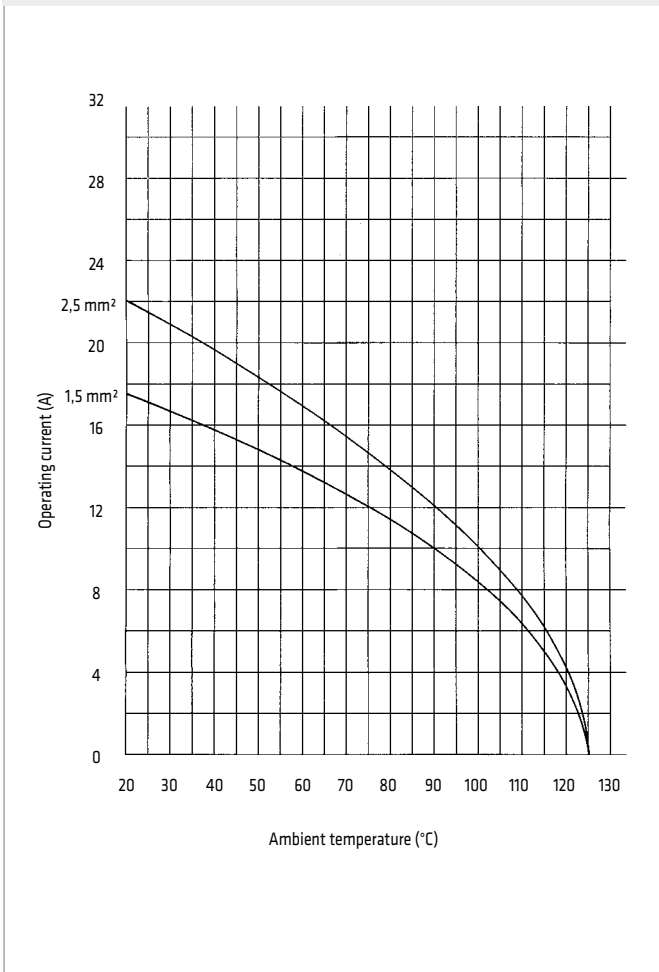

MULTIPOLAR CONNECTORS

GW-HSB range

SCREW CONNECTION 6,12P+ \pm 35A 830V 6kV 3 (35A 1000V 6kV 2)	
Component material:	self-extinguishing technopolymer UL 94 V0 - GWT 960°
Housing material:	aluminium alloy
Contact resistance:	<=0.5 mOhm
Insulation resistance:	>= 10 GOhm
Temperature range:	-40°C +125°C
Electrical connection:	screw: cables from 1.5 to 6mm ² , AWC 16-10
Tightening torque:	1.2 Nm
Conductor stripping:	10.5mm
Type-approvals:	UL (USA), cUL (Canada)
Rated voltage (UL/cUL):	600V
Rated current (UL/cUL):	35A
Lifespan:	>=500 cycles

ELECTRICAL CHARACTERISTICS: LOAD DIAGRAMS

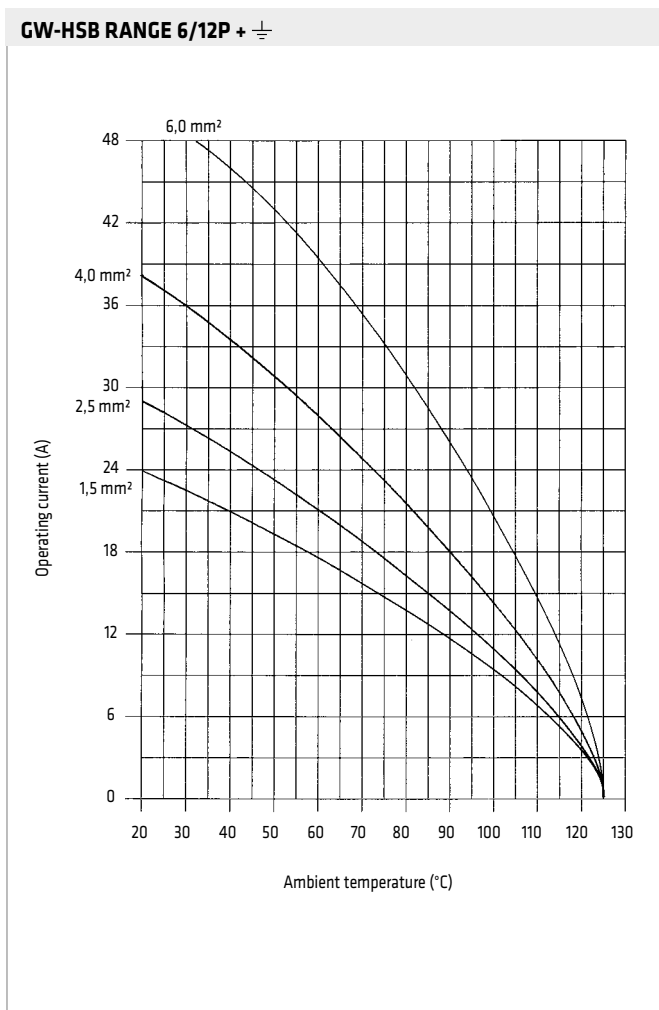

MULTIPOLAR CONNECTORS

GW-K range

SCREW CONNECTION 4/4+2P+ $\frac{1}{2}$ 80A 830V 6kV 3 (80A 1000V 8kV 2) AND 16A 400V 6kV 3 (16A 400/690 6kV 2)	
Component material:	self-extinguishing technopolymer UL 94 V0 - GWT 960°
Housing material:	aluminium alloy
Contact resistance:	<=0.3 - 1.0 mOhm
Insulation resistance:	>= 10 GOhm
Temperature range:	-40°C +125°C
Electrical connection:	screw: cables from 1.5 to 16mm ² / 0.5 to 2.5mm ² , AWG 16-5/20-14
Tightening torque:	2.5 / 0.5 Nm
Conductor stripping:	14 / 7.0mm
Type-approvals:	UL (USA), cUL (Canada)
Rated voltage (UL/cUL):	600V
Rated current (UL/cUL):	80/16A
Lifespan:	>=500 cycles

ELECTRICAL CHARACTERISTICS: LOAD DIAGRAMS

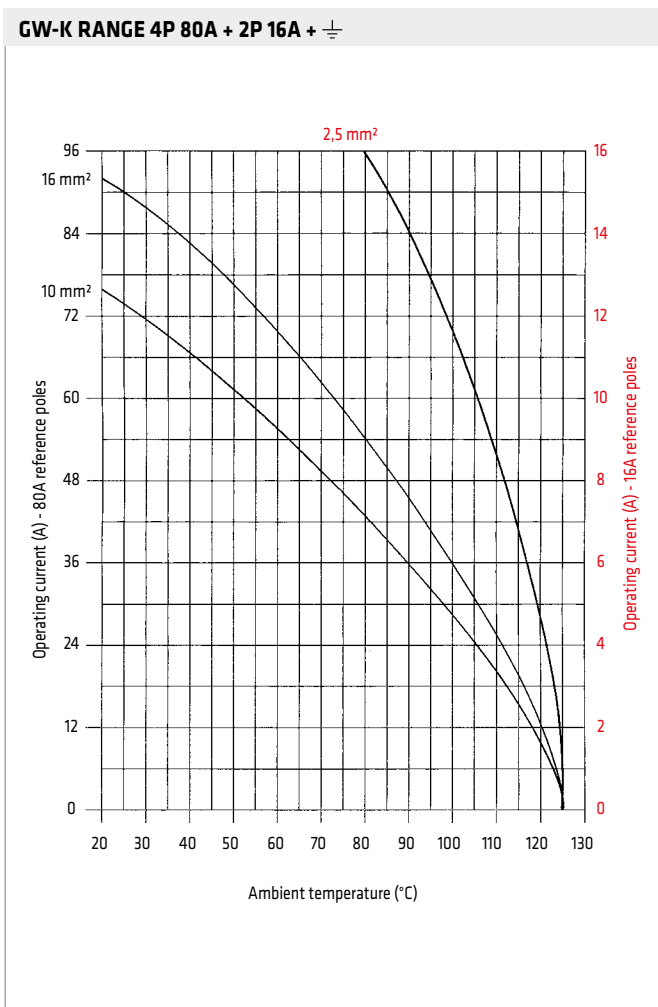

MULTIPOLAR CONNECTORS

SCREW CONNECTION 4+4P+ $\frac{1}{2}$ 80A 500V 6kV 3 (80A 400/690V 6kV 2) AND 16A 500V 6kV 3 (16A 400/690 6kV 2)	
Component material:	self-extinguishing technopolymer UL 94 V0 - GWT 960°
Housing material:	aluminium alloy
Contact resistance:	<=0.3 - 1.0 mOhm
Insulation resistance:	>= 10 GOhm
Temperature range:	-40°C +125°C
Electrical connection:	screw: cables from 1.5 to 16mm ² / 0.5 to 2.5mm ² , AWG 16-5/20-14
Tightening torque:	2.5 / 0.5 Nm
Conductor stripping:	14 / 7.0mm
Type-approvals:	UL (USA), cUL (Canada)
Rated voltage (UL/cUL):	600V
Rated current (UL/cUL):	80/16A
Lifespan:	>=500 cycles

ELECTRICAL CHARACTERISTICS: LOAD DIAGRAMS

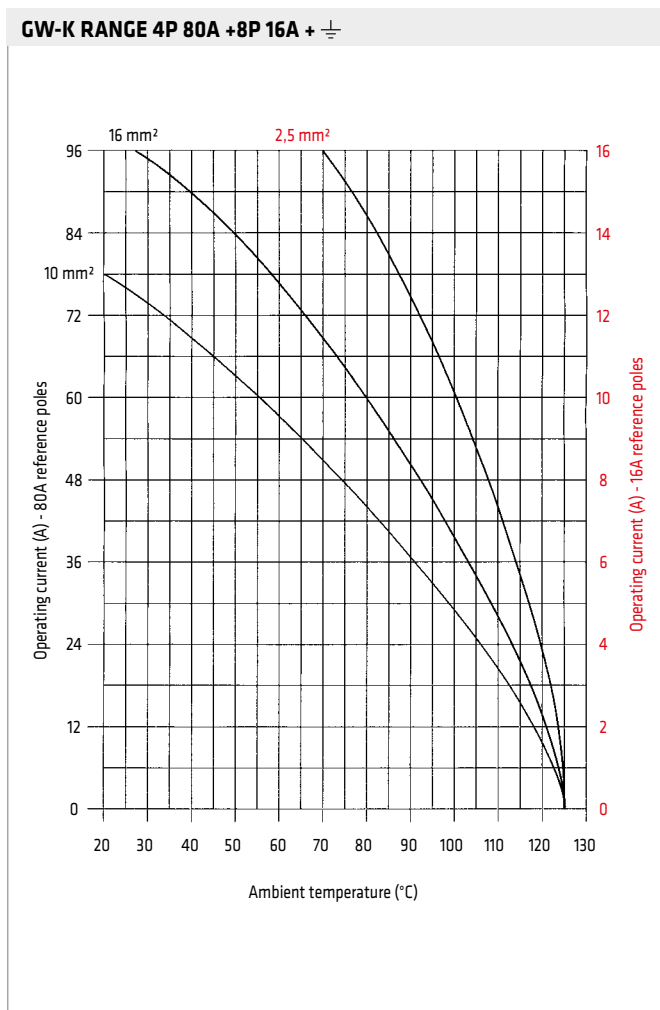

MULTIPOLAR CONNECTORS

GW-Q range

CONNECTION TO BE CRIMPED 5P+ $\frac{1}{2}$ 16A 230/400V 4kV 3 (16A 320/500V 4kV 2)	
Component material:	self-extinguishing technopolymer UL 94 V0 - GWT 960°
Housing material:	aluminium alloy
Contact resistance:	<=0.1 mOhm
Insulation resistance:	>= 10 GOhm
Temperature range:	-40°C +125°C
Electrical connection:	crimped: cables from 0.5 to 2.5mm ² , AWG 20-14
Conductor stripping:	7.5mm
Type-approvals:	UL (USA), cUL (Canada)
Rated voltage (UL/cUL):	600V
Rated current (UL/cUL):	16A
Lifespan:	>=500 cycles

ELECTRICAL CHARACTERISTICS: LOAD DIAGRAMS

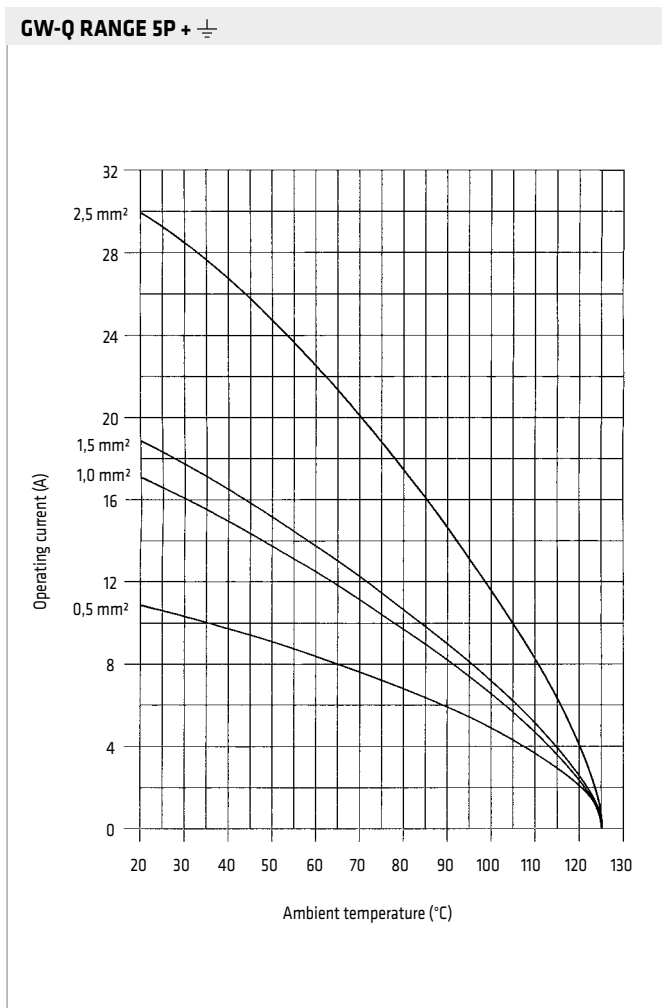

CONNECTION TO BE CRIMPED 12P + $\frac{1}{2}$ 10A 400V 6kV 3 (10A 400/690V 6kV 2)	
Component material:	self-extinguishing technopolymer UL 94 V0 - GWT 960°
Housing material:	aluminium alloy
Contact resistance:	<=0.3 mOhm
Insulation resistance:	>= 10 GOhm
Temperature range:	-40°C +125°C
Electrical connection:	crimped: cables from 0.5 to 2.5mm ² , AWG 20-14
Conductor stripping:	8mm
Electric earth connection:	crimped: cables from 2.5mm ² , AWG 14
Type-approvals:	UL (USA), cUL (Canada)
Rated voltage (UL/cUL):	600V
Lifespan:	>=500 cycles

ELECTRICAL CHARACTERISTICS: LOAD DIAGRAMS

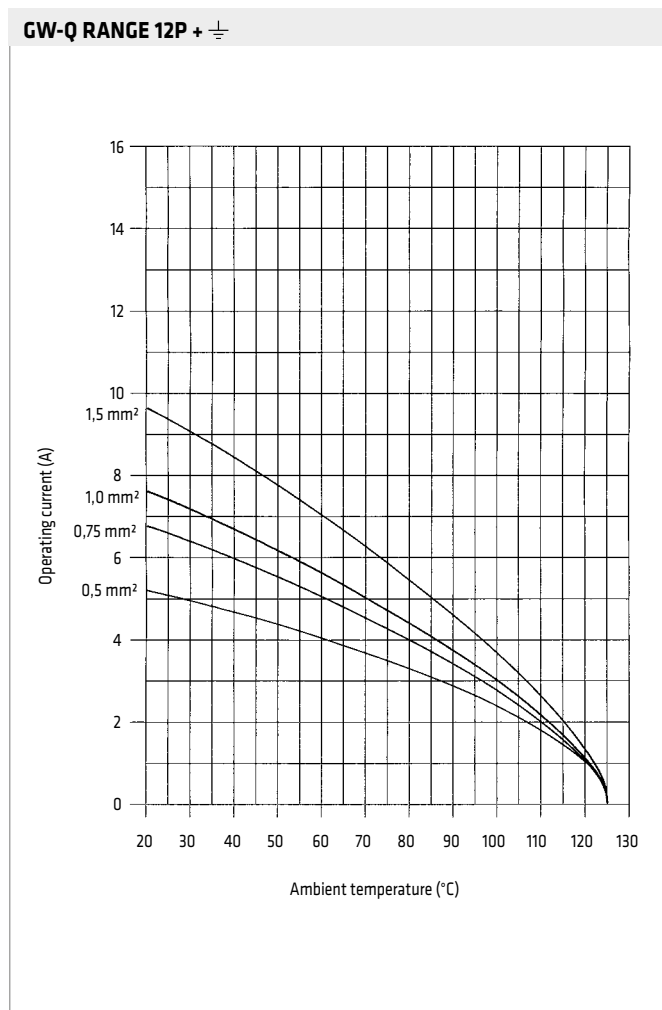

MULTIPOLAR CONNECTORS

CONNECTION TO BE CRIMPED 8P + $\frac{1}{2}$ 16A 500V 6kV 3 (PLASTIC HOUSINGS:16A 400/690V 6kV 2; METAL HOUSINGS: 16A 230/400V 4kV 2)	
Component material:	self-extinguishing technopolymer UL 94 V0 - GWT 960°
Housing material:	aluminium alloy
Contact resistance:	≤ 0.1 mOhm
Insulation resistance:	≥ 10 GOhm
Temperature range:	-40°C +125°C
Electrical connection:	crimped: cables from 0.5 to 2.5mm ² , AWG 20-14
Conductor stripping:	8mm
Type-approvals:	UL (USA), cUL (Canada)
Rated voltage (UL/cUL):	600V
Lifespan:	> 500 cycles

ELECTRICAL CHARACTERISTICS: LOAD DIAGRAMS

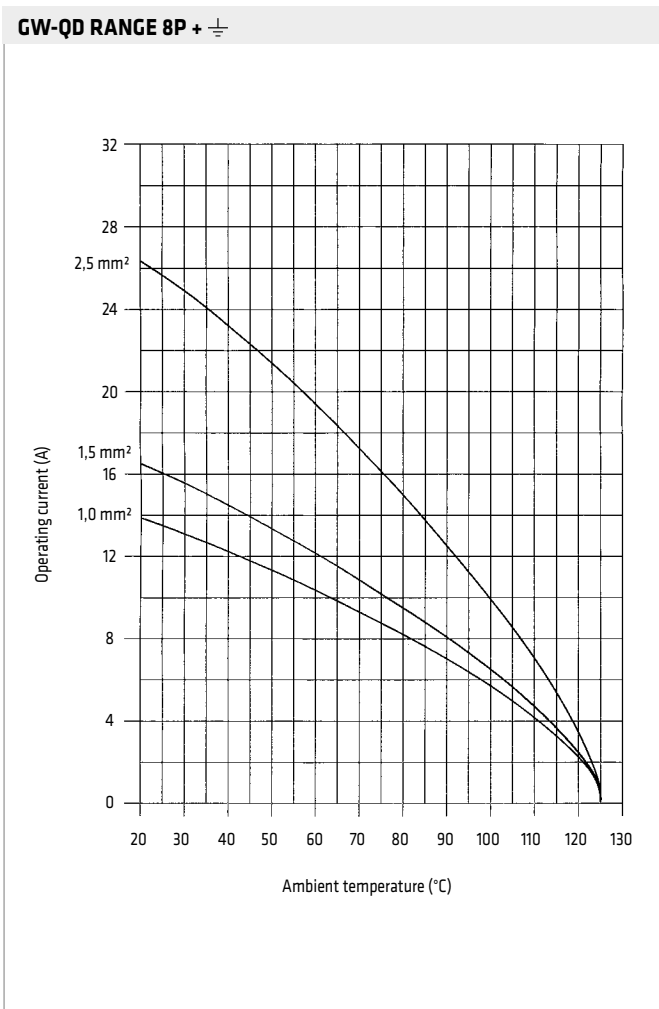

MULTIPOLAR CONNECTORS

CONNECTION TO BE CRIMPED 17P+ $\frac{1}{2}$ 10A 250V 4kV 3 (10A 250/400V 4kV 2)	
Component material:	self-extinguishing technopolymer UL 94 V0 - GWT 960°
Housing material:	aluminium alloy
Contact resistance:	$\leq 0.3 \text{ m}\Omega$
Insulation resistance:	$\geq 10 \text{ G}\Omega$
Temperature range:	-40°C +125°C
Electrical connection:	crimped: cables from 0.14 to 2.5mm ² , AWG 26-14
Conductor stripping:	8mm
Type-approvals:	UL (USA), cUL (Canada)
Rated voltage (UL/cUL):	600V
Lifespan:	≥ 500 cycles

ELECTRICAL CHARACTERISTICS: LOAD DIAGRAMS

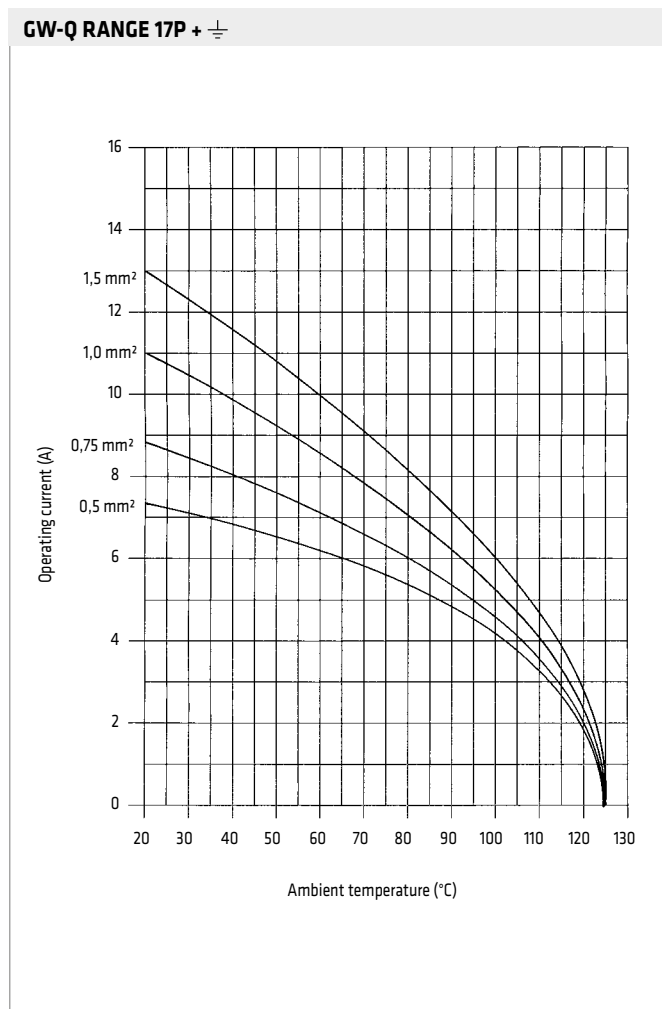

MULTIPOLAR CONNECTORS

CONNECTION TO BE CRIMPED 4+2P+ $\frac{1}{2}$ 40A 250V 4kV 3 AND 10A 250V 4kV 3	
Component material:	self-extinguishing technopolymer UL 94 V0 - GWT 960°
Housing material:	aluminium alloy
Contact resistance:	<=0.3 - 3.0 mOhm
Insulation resistance:	>= 10 GOhm
Temperature range:	-40°C +125°C
Electrical connection:	crimped: cables from 1.5 to 6.0mm ² / 0.14 to 2.5mm ² , AWG 16-10/26-14
Conductor stripping:	7.5mm
Type-approvals:	UL (USA), cUL (Canada)
Rated voltage (UL/cUL):	600V
Lifespan:	>=500 cycles

ELECTRICAL CHARACTERISTICS: LOAD DIAGRAMS

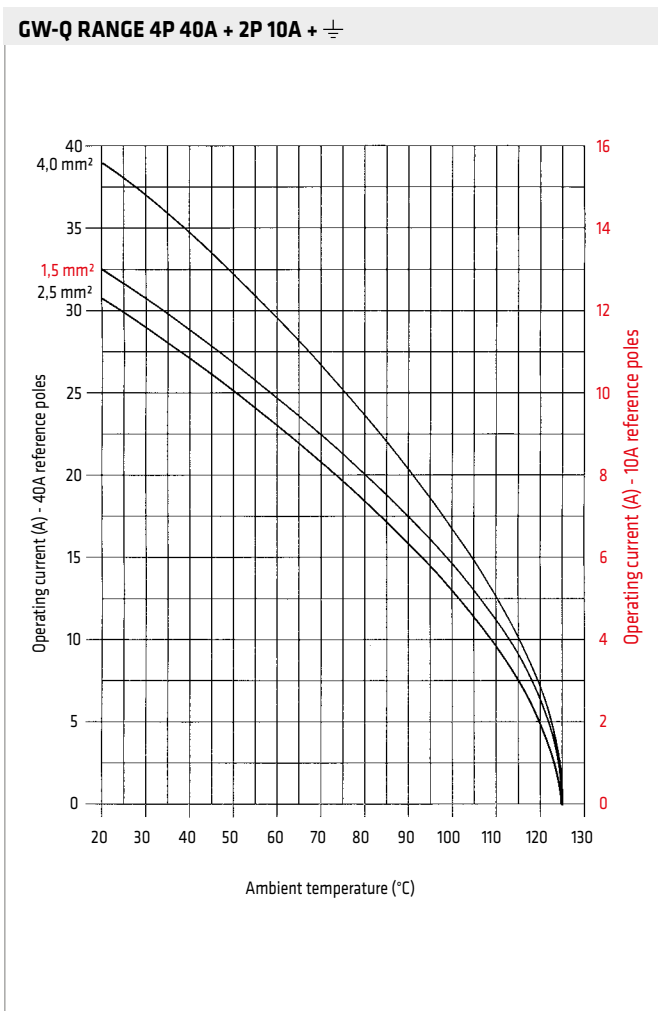

MULTIPOLAR CONNECTORS

Wire connection

Four different types of connection are available for male and female inserts:

- screw connection;
- connection to be crimped;
- screw terminal block connection;
- spring terminal connection.

SCREW TERMINALS

The size of the screws, the cables to be inserted, and the tightening torques are all shown below. In the case of terminals with wire covers, the cable to be inserted need not be prepared in any way (apart from the stripping), while for terminals without wire covers, once the wire has been stripped a pipe terminal is applied.

With regards the conductor traction resistance values according to the screw and wire size, you can see:

Inserts	Maximum wire measurement		Insulation measurement
	mm ²	AWG	mm ²
GW-A	2,5	14	4,5
GW-E, GW-EAV, GW-EHV	2,5	14	7
GW-HSB	6	10	11,5
GW-K	16	5	14

Wire section (mm ²)	1,5	2,5	4	6	10	16
Screw size	M3	M3	M3,5	M4	M4	M6
Minimum traction resistance of the conductor (N)	40	50	60	80	90	100

An increase in the tightening torque does not lead to any notable improvement in contact resistance. The twisting points of the screws have been selected in accordance with EN 60999-1, to produce the optimum behaviour from a mechanical, thermal and electric viewpoint. The conductor or terminal may be damaged if the recommended values are greatly exceeded.

Screw size	Type of insert	Tightening torque (Nm)	Tightening torque (lb.in)	Recommended screwdriver size
M3	GW-A range screw terminals	0,50	4,4	0,5x3
M3	GW-E, GW-EAV, GW-EHV range	0,50	4,4	Ph 0 - 0,8x4
M4	GW-E, GW-EAV, GW-EHV range earth terminal	1,20	10,6	Ph 2 - 1,0x5,5
M4	GW-HSB range screw terminals	1,20	10,6	Ph 1 - 0,8x4
M4	GW-HSB, GW-K range earth terminal	1,20	10,6	Ph 2 - 1,0x5,5
M6	GW-K range screw terminals	2,5	22,1	1,0x5,5

TERMINALS TO BE CRIMPED

A perfect connection to be crimped must be gas-proof: there must be a tight coupling between the copper wires and crimped contact, to guarantee the total protection of the electrical connection against corrosion in aggressive atmospheres. For this purpose, the cables must be crimped on contacts of a size suitable for the conductor section, and the crimping operations must always be carried out using the appropriate tools.

Traction resistance of the crimped conductors:		
Conductor section		Traction resistance
(mm ²)	AWG	N
0,22	24	28
0,25		32
0,32	22	40
0,50	20	60
0,75		85
0,82	18	90
1,00		108
1,30	16	135
1,50		150
2,10	14	200
2,50		230
3,30	12	275
4,00		310
5,30	10	355
6,00		360
8,40	8	370
10,00		380

The crimped connections are then introduced into the contact-holder insert. To take out the crimped connections, just insert a flat 3mm screwdriver in the hole.

SCREW TERMINAL BLOCKS

Pre-arranged with a terminal block at 45° for fixed installations on electric board panels or DIN rail, to facilitate wiring operations and conductor identification. The screw connection with wire cover does not require any conductor preparation.

SPRING TERMINALS

Used for electric connections subject to high stress levels, they allow reduced conductor preparation: usually it only needs to be stripped. No special tools are needed for wiring - just a 3.5x0.5mm screwdriver for opening the terminal.

Housings

STANDARD VERSION

The housings are subdivided into those in self-extinguishing thermoplastic (equipped with anti-ageing sealing gaskets resistant to oils and grease), and those in die-cast painted aluminium alloy (with a monobloc closure device, with stainless steel springs and pins, and galvanised steel or stainless steel levers).

VERSION FOR 830V APPLICATIONS

Housings in die-cast painted aluminium alloy, with anti-ageing sealing gaskets resistant to oils and grease, a monobloc closure device with stainless steel springs and pins and galvanised steel or stainless steel levers, and an additional insulation application inside.

HEAVY DUTY VERSION (HE)

Purposely created for industrial applications with particularly aggressive external agents (such as salty environments): they allow inserts for 830V applications to be used too, and are distinguished by their black colour. Made of die-cast painted aluminium alloy with chromatisation treatment, fluoroelastomer sealing gaskets, and monobloc closure device with stainless steel levers, pins and springs.

EMC VERSION FOR ELECTROMAGNETIC COMPATIBILITY

Made for applications requiring electromagnetic compatibility in accordance with the European Standards relating to device emissions and immunity (EMC directive 2004/108/EC). Made of die-cast, nickel-plated aluminium alloy, special sealing gaskets in a highly conductive material, and a closure device with monobloc levers (in galvanised or stainless steel) and stainless steel springs and pins.