

## Industrial Diesel Generator - PERKINS 550kVA/440kW - 110/230/400V(50/60Hz)



### General Specifications

Standby Power (kVA)	550
Standby Power (kW)	440
Prime Power (kVA)	500
Prime Power (kW)	400
Frequency (Hz)	50/ 60
Cooling System	Water Cooling

- 1) Standby power: The max power available during a variable electrical power sequence, under the stated operating conditions, for which a generating set is capable of delivering in the event of a utility power outage. Overloading isn't permissible.
- 2) Prime Power: The maximum power which a generating set is capable of delivering continuously whilst supplying a variable electrical load. Average load should be 70%. The generator can be overloaded 10% for 1 hour per 12 hrs.

### Dimensions & Weight

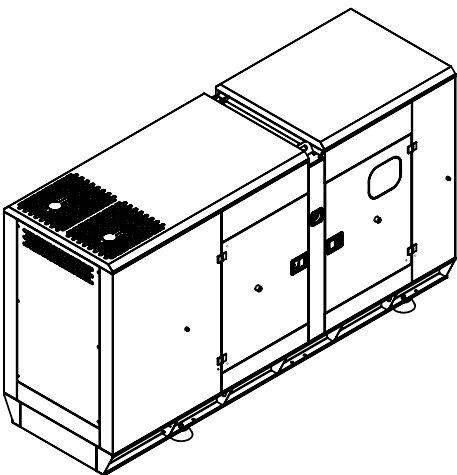

Type	Length (mm)	Width (mm)	Height (mm)	Weight (Kg)	Fuel Tank Capacity
With canopy	5000	1600	2600	4675	1200
Open type	4500	1600	2500	4035	1200

## Engine Specifications

Engine	PERKINS	
Engine Model	2506A- E15TAG2	
Number of Cylinders	6 Inline	
Injection System	Direct	
Compression Ratio	16.0 : 1	
Bore (mm)	137	
Stroke (mm)	171	
Displacement (lt)	15.2	
Air Intake	Turbo Intercooler	
Speed (RPM)	1500	
Oil Capacity (lt)	62	
Standby Power (kW / hp)	478 / 650	
Prime Power (kW / hp)	434 / 590	
Fuel Type	Euro Diesel	
Governor System	Electronic	
Cooling System	Water Cooling	
Coolant Capacity (lt)	58	
Fuel Consumption (lt / h)	Full Load	100
	75% Load	76
	50% Load	53

## Alternator Specifications

Frequency (Hz)	50 / 60	
Power (kVA)	550	
Voltage (V)	110 / 230 / 400	
No. of Phases	3	
Aut. Voltage Regulator (AVR)	AS440	
Voltage Regulation	±1%	
Insulation Class	H	
Protection Standard	IP22-IP23	
Power Factor (Cos)	0.8	

**Technical Specifications**

**ENGINE**

- PERKINS heavy duty diesel engine
- 12V starter and charge alternator
- Replaceable air, fuel and oil filters
- Mechanical governor control
- Tropical type radiator
- Flexible fuel hose
- Oil drain valve and extension hose
- Industrial type silencer and steel compensator
- Maintenance-free starter battery
- Water jacket heater
- 1500 rpm engine speed

**ALTERNATOR**

- IP 21-23 Protection Standard
- H Insulation Class
- 50/60 Hz Frequency
- 4 pole brushless synchronous type alternator
- Automatic Voltage Regulator (AVR)
- 110/230/400V AC Output Voltage - 1500 rpm

**SOUND PROOF CANOPY AND CHASSIS**

- Convenient design for easy lifting and carrying
- High standard sound proof canopy design
- Modular design with easily removable nuts - bolts
- Lockable doors
- Transparent window for watching Control Panel
- Electrostatic powder painted, providing protection against harsh weather conditions
- Emergency STOP button
- Fuel tank inside the chassis
- Anti-vibration wedges (engine - chassis and chassis - ground)

**OPTIONAL**

- Thermal magnetic CB (for automatic models)
- Super Silent Canopy
- Mobile Generator Sets
- Automatic fuel filling system
- Synchronization panel
- 3 Pole and 4 Pole ATS (Automatic Transfer Switch)
- Fuel Heater, Oil Heater
- External fuel tank and automatic fuel filling system
- Fuel - water separator filter
- Remote monitoring and control system



**Control Panel**

# Web based Next Generation Controller



## SPECIFICATIONS

- Diesel and gas genset support
- 400Hz operation support
- 400 event logs, full snapshot
- All parameters front panel editable
- 3 level configuration password
- 128x64 graphical LCD display
- Downloadable languages
- Waveform display of V & I
- Harmonic analysis of V & I
- 16Amp MCB & GCB outputs
- 8 configurable digital inputs
- 6 configurable digital outputs
- 3 configurable analog inputs
- Both CANBUS-J1939 & MPU
- 3 configurable service alarms
- Multiple automatic exerciser
- Weekly operation schedule
- Dual mutual standby with equal aging of gensets
- Manual “speed fine adjust” on selected ECUs
- Automatic fuel pump control
- Disable protections feature
- Excess power protection
- Reverse power protection
- Overload IDMT protection
- Load shedding, dummy load
- Multiple load management
- Current unbalance protection
- Voltage unbalance protection
- Fuel filling & fuel theft alarms
- Battery back-up real time clock
- Idle speed control
- Battery charge run enabled
- Combat mode support
- Multiple nominal conditions
- Contactor & MCB drive
- 4 quadrant genset power counters
- Mains power counters
- Fuel filling counter
- Fuel consumption counter
- Modem diagnostics display
- Configurable through USB, RS-232 and GPRS
- Free configuration program
- Allows SMS controls
- Ready for central monitoring
- Mobile genset support
- Automatic GSM geo-location
- GPS connectivity (RS232)
- Easy USB firmware upgrade
- IP65 rating with optional gasket

## MEASUREMENTS

- Mains & genset PN/PP voltages
- Mains & genset frequency
- Mains & genset phase currents
- Mains & genset neutral currents
- Mains & genset, phase & total, kW, kVA, kVA<sub>r</sub>, pf
- Engine speed
- Battery voltage

## FUNCTIONALITIES

- AMF unit
- ATS unit
- Remote start controller
- Manual start controller
- Engine controller
- Remote display panel

## COMMUNICATION

- USB Device
- RS-232 (2400-57600baud)
- J1939-CANBUS
- Geo-locating through GSM
- GPS support (RS-232)
- Internet Central Monitoring
- SMS message sending
- E-mail sending
- Free PC software: Rainbow Plus
- Modbus RTU
- Modbus TCP/IP