

Industrial Diesel Generator - CUMMINS 88kVA/70.4kW - 110/230/400V(50/60Hz)

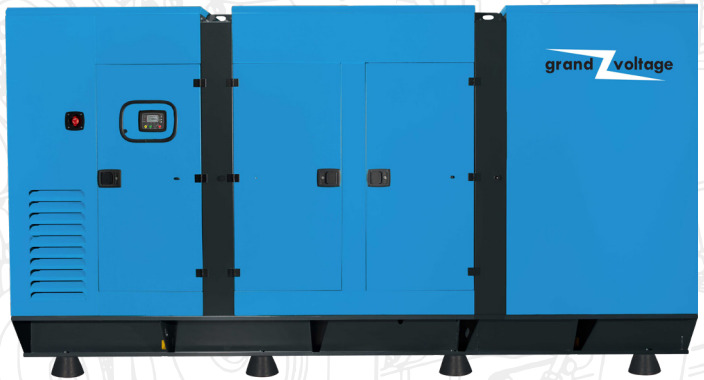

General Specifications

| | |
|---------------------|---------------|
| Standby Power (kVA) | 88 |
| Standby Power (kW) | 70.4 |
| Prime Power (kVA) | 80 |
| Prime Power (kW) | 64 |
| Frequency (Hz) | 50 / 60 |
| Cooling System | Water Cooling |

- 1) Standby power: The max power available during a variable electrical power sequence, under the stated operating conditions, for which a generating set is capable of delivering in the event of a utility power outage. Overloading isn't permissible.
- 2) Prime Power: The maximum power which a generating set is capable of delivering continuously whilst supplying a variable electrical load. Average load should be 70%. The generator can be overloaded 10% for 1 hour per 12 hrs.

Dimensions & Weight

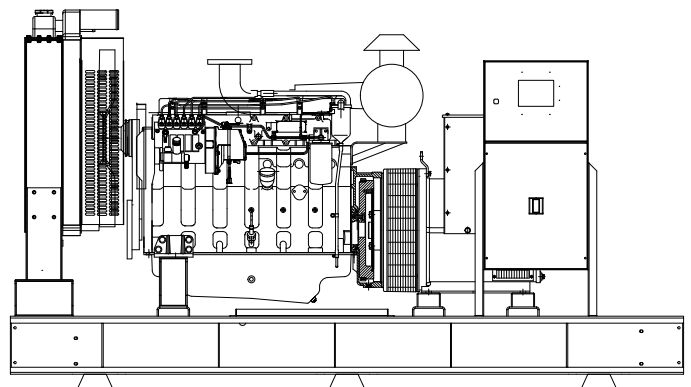
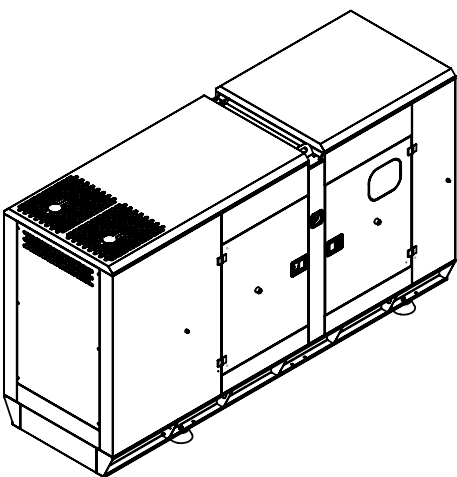

| Type | Length (mm) | Width (mm) | Height (mm) | Weight (Kg) | Fuel Tank Capacity |
|-------------|-------------|------------|-------------|-------------|--------------------|
| With canopy | 2800 | 1000 | 1500 | 1270 | 195 |
| Open type | 2350 | 1000 | 1450 | 1076 | 195 |

Engine Specifications

| | | |
|---------------------------|-------------------|------|
| Engine | CUMMINS | |
| Engine Model | 4BTA3.9-G11 | |
| Number of Cylinders | 4 Inline | |
| Injection System | Direct | |
| Compression Ratio | 17.3 : 1 | |
| Bore (mm) | 102 | |
| Stroke (mm) | 120 | |
| Displacement (lt) | 3.9 | |
| Air Intake | Turbo Aftercooler | |
| Speed (RPM) | 1500 | |
| Oil Capacity (lt) | 10.9 | |
| Standby Power (kW / hp) | 80 / 107 | |
| Prime Power (kW / hp) | 70 / 93 | |
| Fuel Type | Euro Diesel | |
| Governor System | Electronic | |
| Cooling System | Water Cooling | |
| Coolant Capacity (lt) | 8.3 | |
| Fuel Consumption (lt / h) | Full Load | 17.6 |
| | 75% Load | 13.2 |
| | 50% Load | 9.1 |

Alternator Specifications

| | | |
|------------------------------|-----------------|--|
| Frequency (Hz) | 50 / 60 | |
| Power (kVA) | 88 | |
| Voltage (V) | 110 / 230 / 400 | |
| No. of Phases | 3 | |
| Aut. Voltage Regulator (AVR) | AS440 | |
| Voltage Regulation | ±1% | |
| Insulation Class | H | |
| Protection Standard | IP22-IP23 | |
| Power Factor (Cos) | 0.8 | |

Technical Specifications

ENGINE

- CUMMINS heavy duty diesel engine
- 12V starter and charge alternator
- Replaceable air, fuel and oil filters
- Mechanical governor control
- Tropical type radiator
- Flexible fuel hose
- Oil drain valve and extension hose
- Industrial type silencer and steel compensator
- Maintenance-free starter battery
- Water jacket heater
- 1500 rpm engine speed

ALTERNATOR

- IP 21-23 Protection Standard
- H Insulation Class
- 50/60 Hz Frequency
- 4 pole brushless synchronous type alternator
- Automatic Voltage Regulator (AVR)
- 110/230/400V AC Output Voltage - 1500 rpm

SOUND PROOF CANOPY AND CHASSIS

- Convenient design for easy lifting and carrying
- High standard sound proof canopy design
- Modular design with easily removable nuts - bolts
- Lockable doors
- Transparent window for watching Control Panel
- Electrostatic powder painted, providing protection against harsh weather conditions
- Emergency STOP button
- Fuel tank inside the chassis
- Anti-vibration wedges (engine - chassis and chassis - ground)

OPTIONAL

- Thermal magnetic CB (for automatic models)
- Super Silent Canopy
- Mobile Generator Sets
- Automatic fuel filling system
- Synchronization panel
- 3 Pole and 4 Pole ATS (Automatic Transfer Switch)
- Fuel Heater, Oil Heater
- External fuel tank and automatic fuel filling system
- Fuel - water separator filter
- Remote monitoring and control system



Control Panel

Web based Next Generation Controller



SPECIFICATIONS

- Diesel and gas genset support
- 400Hz operation support
- 400 event logs, full snapshot
- All parameters front panel editable
- 3 level configuration password
- 128x64 graphical LCD display
- Downloadable languages
- Waveform display of V & I
- Harmonic analysis of V & I
- 16Amp MCB & GCB outputs
- 8 configurable digital inputs
- 6 configurable digital outputs
- 3 configurable analog inputs
- Both CANBUS-J1939 & MPU
- 3 configurable service alarms
- Multiple automatic exerciser
- Weekly operation schedule
- Dual mutual standby with equal aging of gensets
- Manual “speed fine adjust” on selected ECUs
- Automatic fuel pump control
- Disable protections feature
- Excess power protection
- Reverse power protection
- Overload IDMT protection
- Load shedding, dummy load
- Multiple load management
- Current unbalance protection
- Voltage unbalance protection
- Fuel filling & fuel theft alarms
- Battery back-up real time clock
- Idle speed control
- Battery charge run enabled
- Combat mode support
- Multiple nominal conditions
- Contactor & MCB drive
- 4 quadrant genset power counters
- Mains power counters
- Fuel filling counter
- Fuel consumption counter
- Modem diagnostics display
- Configurable through USB, RS-232 and GPRS
- Free configuration program
- Allows SMS controls
- Ready for central monitoring
- Mobile genset support
- Automatic GSM geo-location
- GPS connectivity (RS232)
- Easy USB firmware upgrade
- IP65 rating with optional gasket

MEASUREMENTS

- Mains & genset PN/PP voltages
- Mains & genset frequency
- Mains & genset phase currents
- Mains & genset neutral currents
- Mains & genset, phase & total, kW, kVA, kVA_r, pf
- Engine speed
- Battery voltage

FUNCTIONALITIES

- AMF unit
- ATS unit
- Remote start controller
- Manual start controller
- Engine controller
- Remote display panel

COMMUNICATION

- USB Device
- RS-232 (2400-57600baud)
- J1939-CANBUS
- Geo-locating through GSM
- GPS support (RS-232)
- Internet Central Monitoring
- SMS message sending
- E-mail sending
- Free PC software: Rainbow Plus
- Modbus RTU
- Modbus TCP/IP