

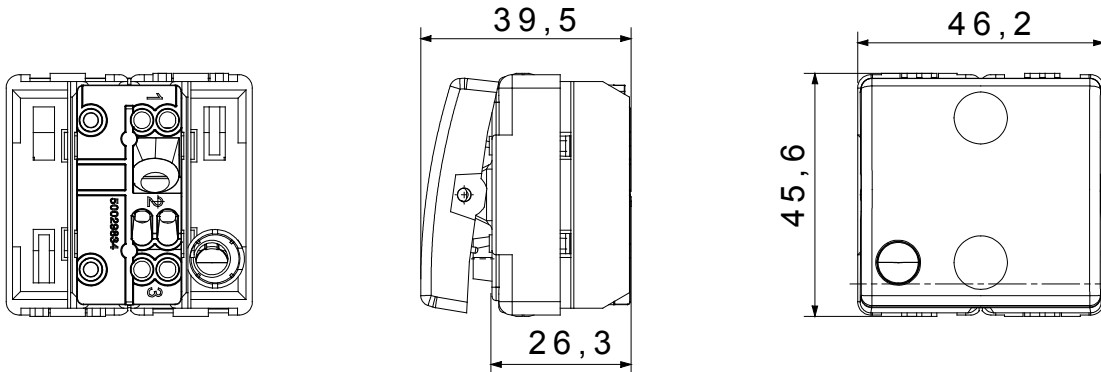

The System modular devices allow the creation of infinite combinations of devices and plates, through a complete range that covers all design, functional and installation needs. Colours and finishes: satin black, elegant and classy. The range includes control units, socket-outlets, breakers, indicators, connectors and devices for the control, safety and comfort of your home.

Category	Push-button	Button key	With diffuser
Colour	Black	Description	1P NO - 10 A - illuminable
Voltage	250 V ac	Standard	EN 60669-1
Resistance at test voltage	2000 V at 50 Hz for 1 minute	Insulation resistance	> 5 MOhm
Wiring terminals	With screw	Prolonged operation switch (no.of position changes)	40.000 at In 250 V ac cosφ=0,6
Terminal grip on cable traction	> 50 N	Terminal tightening capacity stranded cables (mm ²)	min. 0,75 - max. 2x4
Terminal tightening capacity solid cables (mm ²)	min. 0,5 - max. 2x2,5	Thermo-pressure with ball	125 °C
Glow Wire Test	850 °C	No. SYSTEM modules	2
Material	Technopolymer	Electrocod	0130

DIMENSIONAL



TECHNICAL SYMBOLOGY



STANDARDS/APPROVALS

