

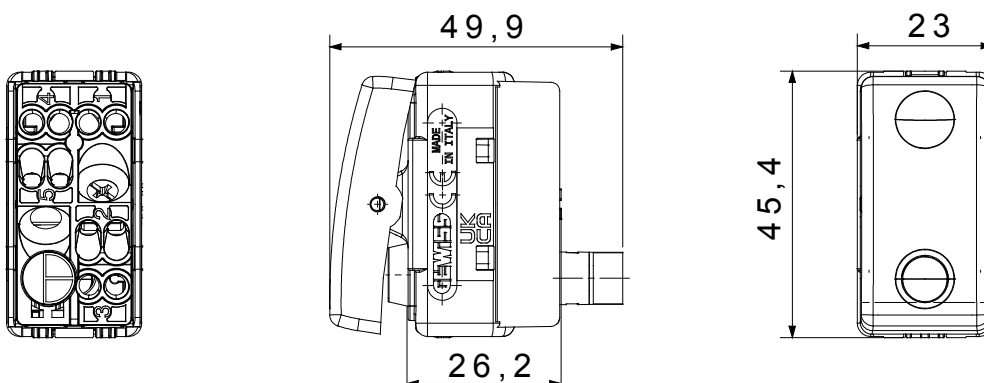

The System modular devices make it possible to create infinite combination between devices and plates, thanks to a complete range that is able to satisfy all design, functional and installation requirements. Colour and finiture: glossy white, bright and versatile
The range includes commands, socket- outlets, protection, indicators, connectors and devices for the control, safety and comfort of your home.

Category	Push-button	Button key	With replaceable neutral lens
Symbol	-	Colour	White
Description	1P NO - 10 A backlit	Voltage	250 V ac
Signalling unit	LED 12/24Vac/dc (0,4W) white color	Standard	EN 60669-1
Resistance at test voltage	2000 V at 50 Hz for 1 minute	Insulation resistance	> 5 MOhm
Wiring terminals	With screw	Prolonged operation switch (no.of position changes)	40.000 at In 250 V ac cosφ=0,6
Thermo-pressure with ball	125 °C	Glow Wire Test	850 °C
Terminal grip on cable traction	> 50 N	Terminal tightening capacity stranded cables (mm ²)	min. 0,75 - max. 2x4
Terminal tightening capacity solid cables (mm ²)	min. 0,5 - max. 2x2,5	No. SYSTEM modules	1
Material	Technopolymer	Electrocod	0130

DIMENSIONAL



TECHNICAL SYMBOLOGY



STANDARDS/APPROVALS

