



**INSTALLATION MANUAL
OF REPLACEMENT
SOLAR MODULES**

CONTENTS

1.0 GENERAL INFORMATION	3
1.1 INSTALLATION MANUAL DISCLAIMER	3
1.2 LIMITATION OF LIABILITY	3
2.0 SAFETY PRECAUTIONS	3
3.0 MECHANICAL / ELECTRICAL SPECIFICATIONS.....	4
4.0 UNPACKING AND STORAGE	5
5.0 MODULE INSTALLATION	5
5.1 MODULE WIRING	8
5.2 GROUNDING.....	9
6.0 MOUNTING INSTRUCTIONS	10
6.1 MOUNTING METHOD: BOLTING	10
6.2 MOUNTING METHOD: CLAMPING	13
6.3 INSERTION SYSTEMS	16
6.4 MOUNTING METHODS WITH SINGLE-AXIS TRACKER	17
7.0 MAINTENANCE	18
8.0 MODULE CLEANING GUIDELINES	18
ANNEX A: MECHANICAL AND ELECTRICAL RATINGS.....	20
AMENDED EDITIONS AND DATES.....	23

1.0 GENERAL INFORMATION

This general manual provides important safety information relating to the installation, maintenance and handling of CS-series solar modules.

Professional installer must read these guidelines carefully and strictly follow these instructions. Failure to follow these instructions may result in death, injury or property damage. The installation and handling of PV modules require professional skills and should only be performed by qualified professionals. The installers must inform end-users (consumers) the aforesaid information accordingly. The word "module" or "PV module" used in this manual refers to one or more CS-series solar modules.

This manual is only valid for the classic module types CS5AH-M, CS5PH-M, CS5PH-P, CS6AH-P, CS6AH-M, CS6PH-P, CS6PH-M, CS6XH-P, CS6XH-M, CS5A-M-PLUS, CS5P-M-PLUS, CS6A-P-PLUS, CS6P-P-PLUS and CS6X-P-PLUS.

Please retain this manual for future reference. We recommend checking www.csisolar.com regularly for the most updated version.

1.1 INSTALLATION MANUAL DISCLAIMER

The information contained in this manual is subject to change by Canadian Solar without prior notice. Canadian Solar gives no warranty of any kind whatsoever, either explicitly or implicitly, with respect to the information contained herein.

In the event of any inconsistency among different language versions of this document, the English version shall prevail. Please refer to our product lists and documents published on our website at: www.csisolar.com as these lists are updated on a regular basis.

1.2 LIMITATION OF LIABILITY

Canadian Solar shall not be held responsible for damages of any kind, including – without limitation – bodily harm, injury or damage to property, in connection with handling PV modules, system installation, or compliance or non-compliance with the instructions set forth in this manual.

2.0 SAFETY PRECAUTIONS



Warning

Before attempting to install, wire, operate and/or service the module and other electrical equipment, all instructions should be read and understood. PV module connectors pass direct current (DC) when exposed to sunlight or other light sources. Contact with electrically active parts of the module, such as terminals, can result in injury or death, irrespective of whether or not the module and the other electrical equipment have been connected.



Avertissement

Toutes les instructions devront être lues et comprises avant de procéder à l'installation, le câblage, l'exploitation et/ou l'entretien des panneaux. Les interconnexions des panneaux conduisent du courant continu (CC) lorsque le panneau est exposé à la lumière du soleil ou à d'autres sources lumineuses. Tout contact avec des éléments sous tension du panneau tels que ses bornes de sortie peut entraîner des blessures ou la mort, que le panneau soit connecté ou non.

General Safety

All modules must be installed by licensed electricians in accordance to the applicable electrical codes such as, the latest National Electrical Code (USA) or Canadian Electric Code (Canada) or other national or international applicable electrical codes.



Protective clothing (non-slip gloves, clothes, etc.) must be worn during installation to prevent direct contact with 30 V DC or greater, and to protect hands from sharp edges.



Prior to installation, remove all metallic jewelry to prevent accidental exposure to live circuits.



When installing modules in light rain, morning dew, take appropriate measures to prevent water ingress into the connector.



Do not allow children or unauthorized persons near the installation site or module storage area.

- **Do not** install modules in strong wind.
- Use electrically insulated tools to reduce the risk of electric shock.
- If the disconnects and over current protection devices (OCPDs) cannot be opened or the inverter cannot be powered down, cover the fronts of the modules in the PV array with an opaque material to stop the production of electricity when installing or working on a module or wiring.
- **Do not** use or install damaged modules
- Contact with module surfaces or frames may cause electric shock if the front glass is broken or the backsheet is torn.
- The PV module does not contain any serviceable parts. Do not attempt to repair any part of the module.
- Keep the junction box cover closed at all times.
- **Do not** disassemble a module or remove any module part.
- **Do not** artificially concentrate sunlight on a module.

- **Do not** connect or disconnect modules when current from the modules or an external source is present.

3.0 MECHANICAL / ELECTRICAL SPECIFICATIONS

Module electrical ratings are measured under Standard Test Conditions (STC) of 1000 W/m² irradiance, with an AM1.5 spectrum, and a cell temperature of 25°C. Detailed electrical and mechanical characteristics of Canadian Solar crystalline silicon PV modules can be found in Annex A (Module Specifications) on www.csisolar.com. Main electrical characteristics at STC are also stated on each module label. Please refer to the datasheet or the product nameplate for the maximum system voltage.

Under certain conditions, a module may produce more current or voltage than its Standard Test Conditions rated power. As a result, the module short-circuit current under STC should be multiplied by 1.25, and a correction factor should be applied to the open-circuit voltage (see Table 1 below), when determining component ratings and capacities. Depending on your local regulations, an additional 1.25 multiplier for the short-circuit current (giving a total multiplier of 1.56) may be applicable when sizing conductors and fuses.

Table 1: Low temperature correction factors for open-circuit voltage

Lowest Expected Ambient Temperature (°C/°F)	Correction Factor
24 to 20 / 76 to 68	1.02
19 to 15 / 67 to 59	1.04
14 to 10 / 58 to 50	1.06
9 to 5 / 49 to 41	1.08
4 to 0 / 40 to 32	1.10
-1 to -5 / 31 to 23	1.12
-6 to -10 / 22 to 14	1.14
-11 to -15 / 13 to 5	1.16
-16 to -20 / 4 to -4	1.18
-21 to -25 / -5 to -13	1.20
-26 to -30 / -14 to -22	1.21
-31 to -35 / -23 to -31	1.23
-36 to -40 / -32 to -40	1.25

Alternatively, a more accurate correction factor for the open-circuit voltage can be calculated using the following formula:

$$C_{Voc} = 1 - \alpha_{Voc} \times (25 - T)$$

T is the lowest expected ambient temperature at the

system installation site.

α_{Voc} is the voltage temperature coefficient of the selected module (refer to corresponding datasheet).

Electrical calculations and design must be performed by a competent engineer or consultant.

Please contact Canadian Solar’s technical support team for additional information pertaining to engineering optimization and approval of project specific module string lengths.

4.0 UNPACKING AND STORAGE

NOTICE

PRECAUTIONS

- Modules should be stored in a dry and ventilated environment to avoid direct sunlight and moisture. If modules are stored in an uncontrolled environment, the storage time should be less than 3 months and extra precautions should be taken to prevent connectors from being exposed to moisture or sunlight, like using connector endcaps.
- Unpack module pallets carefully, following the steps shown on the pallet. Unpack, transport and store the modules with care.
- Modules must always be unpacked and installed by two people. Always use both hands when handling modules.

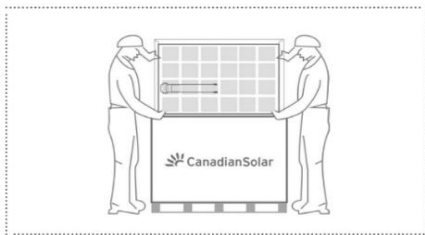

- **Do not** lift modules by their wires or junction box, lift them by the frame.
- Stacks of modules should contain no more than 12 modules, and the frames should be aligned.
- **Do not** place excessive loads on the module or twist the module frame.
- **Do not** stand, step, walk and/or jump on modules under any circumstances. Localized heavy loads may

cause severe micro-cracks at cell level, which in turn may compromise module reliability and void Canadian Solar’s warranty.



- **Do not** leave the module backsheet directly in contact with the support structure underneath when handling or installing the module.
- **Do not** carry modules on your head.
- **Do not** drop or place objects (such as tools) on the modules.
- **Do not** use sharp instruments on the modules. Particular care should be taken to avoid module backsheets being damaged by sharp objects, as scratches may directly affect product safety.
- **Do not** leave modules unsupported or unsecured.
- **Do not** change the wiring of bypass diodes.
- Keep all electrical contacts clean and dry at all times.
- **Do not** expose the modules and its electrical contacts to any unauthorized chemical substance (e.g. oil, lubricant, pesticide, etc.).

PRODUCT IDENTIFICATION

Each module has three identical barcodes (one in the laminate under the front glass, the second on the rear side of the module and the third on the frame) that act as a unique identifier. Each module has a unique serial number containing 13 (pre-March 2013) or 14 (post-March 2013) digits.

A nameplate is also affixed to the rear of each module. This nameplate specifies the model type, as well as the main electrical and safety characteristics of the module.

5.0 MODULE INSTALLATION



PRECAUTIONARY MEASURES AND GENERAL SAFETY

- Prior to installing modules please obtain information

about any requirements and necessary approvals for the site, installation and inspection from the relevant authorities.

- Check applicable building codes to ensure that the construction or structure (roof, facade, support, etc.) can bear the module system load.
- Canadian Solar modules have been qualified for Application Class A (equivalent to Safety Class II requirements). Modules rated under this class should be used in systems operating at voltage above 50V or power above 240W, where general contact access is anticipated.
- Canadian Solar modules have been certified as Type 1 or Type 4 according to UL 1703, Type1 or Type 2 according to UL 61730 and Class C according to IEC 61730-2 for fire class performance, please refer to the datasheet or the product nameplate for the detailed types.
- Consult your local authority for guidelines and requirements for building or structural fire safety.

UL 1703 SYSTEM FIRE RATING REQUIREMENTS

- Photovoltaic systems composed of UL 1703 or UL 61730 certified modules mounted on a UL 2703 certified mounting system should be evaluated in combination with roof coverings in accordance with UL 1703 or UL 61730 standard, with respect to meeting the same fire classification as the roof assembly.
- Mounting systems with a System Fire Class Rating (Class A, B or C), tested in conjunction with "Type 1" or "Type 2" or "Type 4" fire rated modules, are considered acceptable for use with Canadian Solar modules, provided that the mounting system does not violate any other requirements of this manual.
- Any mounting system limitations on inclination or accessories required to maintain a specific System Fire Class Rating should be clearly specified in the installation instructions and UL 2703 certification of the mounting system supplier.
- When installing modules, ensure the assembly is mounted over a fire-resistant roof covering rated for the application.

- The fire rating for this module is only valid when the product is installed as specified in the mechanical mounting instructions.

ENVIRONMENTAL CONDITIONS

- The module is intended for use in general open-air climates, as defined in IEC 60721-2-1: Classification of environmental conditions Part 2-1: Environmental conditions appearing in nature. Temperature and humidity.
- Please consult the Canadian Solar technical support department for more information on the use of modules in special climates, such as an altitude greater than 2000m.



Do not install modules near open flames or flammable materials.



Do not immerse modules in water or constantly expose modules to water (either fresh or salt, i.e. from fountains, sea spray).

- Exposing modules to salt (i.e. marine environments) or sulfur (i.e. sulfur sources, volcanoes) incurs the risk of module corrosion.
- Do not expose modules and their connectors to any unauthorized chemical substances (e.g. oil, lubricant, pesticide, etc.), as modules may incur damages.
- Canadian Solar modules have passed salt mist corrosion resistance test according to IEC 61701, but the corrosion may still occur on where the modules frame is connected to the bracket or where the grounding is connected. Should the installation location be near the ocean, Canadian Solar recommends stainless steel or aluminum materials be used in the areas with direct contact with the PV modules, and the connection point should be protected with anti-corrosion measures. For more information, please contact Canadian Solar technical support team.
- Failure to comply with these instructions will void Canadian Solar warranty.

INSTALLATION REQUIREMENTS

- Ensure that the module meets the general technical system requirements.

- Ensure that other systems components do not damage the module mechanically or electrically.
- Modules can be wired in series to increase voltage or in parallel to increase current. To connect modules in series, connect the cables from the positive terminal of one module to the negative terminal of the next module. To connect in parallel, connect the cables from the positive terminal of one module to the positive terminal on the next module.
- The quantity of bypass diodes in the module's junction box provided may vary depending on the model series.
- Only connect the quantity of modules that corresponds to the voltage specifications of the inverters used in the system. In addition modules must not be connected together to create a voltage higher than the maximum permitted system voltage stated on the module nameplate, even under the worst local temperature conditions (see Table 1 for the correction coefficients that apply to open-circuit voltage).
- A maximum of two strings can be connected in parallel without using an over-current protection device (fuses, etc.) incorporated in series within each string. Three or more strings can be connected in parallel if an appropriate and certified over-current protection device is installed in series within each string. And it shall be ensured in the PV system design that the reverse current of any particular string is lower than the module maximum fuse rating at any circumstances.
- Only modules with similar electrical parameters should be connected in the same string to avoid or minimize mismatch effects in arrays.
- To minimize risk in the event of an indirect lightning strike, avoid forming loops with the wiring when designing the system.
- The recommended maximum series fuse rating is stated in a table in the Annex A.
- Modules should be safely fixed to bear all expected loads, including wind and snow loads.
- A minimum clearance of 6.5 mm (0.25 in) between modules is required to allow for thermal expansion of the frames.

- The small drainage holes on the underside of the module must not be blocked.

OPTIMUM ORIENTATION AND TILT

- To maximize the annual yield, please calculate the optimum orientation and tilt for PV modules in that specific installation site. The highest yields are achieved when sunlight shines perpendicularly onto the PV modules.

AVOID SHADING

- Modules shall not be permanently shaded (including partial shading, spot shading, even shading or uneven shading) under any circumstance. Permanent shading includes shading of the same cell, cell row, or module portion for extended and repeated periods of time (e.g. more than 200 daylight hours over the warranted service lifetime). Power dissipated in fully or partially shaded cells will result in power loss, reduced yield and can cause localized overheating, which in turn may negatively impact the module service lifetime. Permanent shading may cause accelerated ageing of the encapsulation material and place thermal stress on the bypass diodes. This would void the module's warranty unless properly mitigated through the use of Module Level Power Electronic (MLPE) devices.

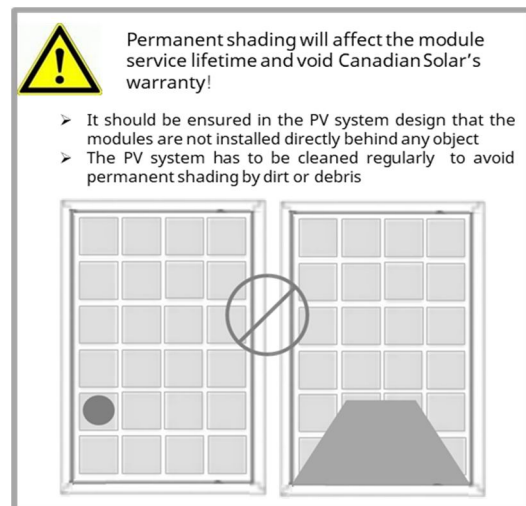

- Regular maintenance is required to keep modules clean. Particular measures should be taken to avoid permanent shading from dirt or debris (e.g., plants, bird droppings, etc).

- Do not install modules directly behind any object (e.g., tree, antenna, etc) to prevent occurrence of permanent shading.
- Even temporary partial shading will reduce yield. A module can be considered to be unshaded if its entire surface is free from shading all year round, including on the shortest day of the year.

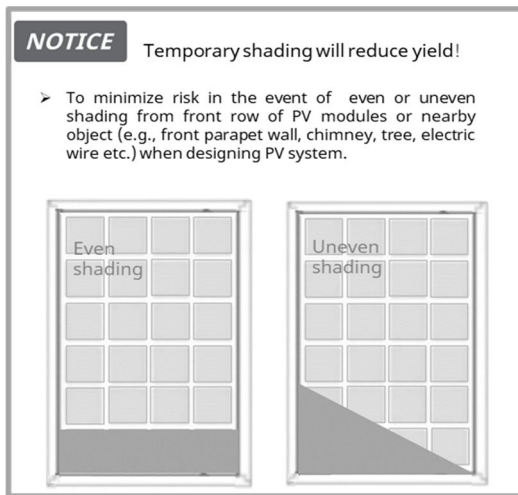

RELIABLE VENTILATION

- Sufficient clearance (at least 102 mm (4.02 in)) between the module frame and the mounting surface is required to allow cooling air to circulate around the back of the module. This also allows condensation or moisture to dissipate.
- According to UL 1703, any other specific clearance required for maintaining a system fire rating should prevail. Detailed clearance requirements pertaining to system fire ratings must be provided by your racking supplier.

5.1 MODULE WIRING

CORRECT WIRING SCHEME

- Cable management scheme should be reviewed and approved by the EPC contractor; in particular required cable lengths should be cross-checked considering the specificities of the tracker structure like bearing house gaps. If longer cable or additional jumper cable is requested, please contact Canadian Solar's sales representative in advance.
- Ensure that the wiring is correct before starting up the

system. If the measured open circuit voltage (Voc) and short-circuit current (Isc) differ from the specifications, this indicates that there is a wiring fault.

- When modules have been installed but the system has not been connected to the grid yet, each module string should be kept under open-circuit conditions and proper actions should be taken to avoid dust and moisture penetration inside the connectors.
- The maximum distance between two adjacent module frames should be within 50 mm (1.96in) for the side with mounting clamps, and within 25 mm (0.98in) for the side without mounting clamps, in order to meet the system cable scheme.

CORRECT CONNECTION OF PLUG CONNECTORS

- Make sure that all connections are safe and properly mated. The PV connector should not be subject to stress from the exterior. Connectors should only be used to connect the circuit. They should never be used to turn the circuit on and off.
- Connectors are not waterproof when unmated. When installing modules, connector should be connected to each other as soon as possible or appropriate measures (like using connector endcaps) should be taken to avoid moisture and dust penetrating into the connector.
- Do not connect different connectors (manufacturer and type) together.
- Do not clean or precondition the connectors using lubricants or any unauthorized chemical substances.

USE OF SUITABLE MATERIALS

- Only use dedicated solar cable and suitable connectors (wiring should be sheathed in a sunlight-resistant conduit or, if exposed, should itself be sunlight-resistant) that meet local fire, building and electrical regulations. Please ensure that all wiring is in perfect electrical and mechanical condition.
- Installers may only use single-conductor cable listed and labeled as USE-2 or PV wire which is 90°C wet rated in North America, and single conductor cable, 2.5-16 mm² (5-14 AWG), 90°C wet rated in other areas (i.e. TUV 2PFG1169 or EN50618 approved), with proper insulation

which is able to withstand the maximum possible system open-circuit voltage.

- Only copper conductor material should be used. Select a suitable conductor gauge to minimize voltage drop and ensure that the conductor ampacity complies with local regulations (i.e. NEC 690.8(D)).

CABLE AND CONNECTOR PROTECTION

- Secure the cables to the mounting system using UV-resistant cable ties. Protect exposed cables from damage by taking appropriate precautions (e.g. placing them inside a metallic raceway like EMT conduit). Avoid exposure to direct sunlight.
- A minimum bending radius of 60 mm (2.36 in) is required when securing the junction box cables to the racking system.
- Protect exposed connectors from weathering damage by taking appropriate precautions. Avoid exposure to direct sunlight.
- Do not place connectors in locations where water could easily accumulate.

5.2 GROUNDING

- For grounding requirements in North America, a module with exposed conductive parts is considered to comply with UL 1703 only when it is electrically

grounded in accordance with both the instructions presented below and the requirements of the National Electrical Code. Any grounding means used with Canadian Solar modules should be NRTL certified to UL 467 and UL 2703 standards. Please consult our technical service team for the formal approval process.

- For grounding requirements in other areas, although the modules are certified to Safety Class II, we recommend them to be grounded and that module installation should comply with all applicable local electrical codes and regulations. Grounding connections should be installed by a qualified electrician. Connect module frames together using adequate grounding cables: the use of 4-14 mm² (AWG 6-12) copper wire is recommended. Holes provided for this purpose are identified with a grounding symbol \equiv (IEC 61730-1). All conductive connection junctions must be firmly fixed.
- Do not drill any extra ground holes for convenience as this will void the modules warranty.
- All bolts, nuts, flat washers, lock washers and other relevant hardware should be made of stainless steel, unless otherwise specified.
- Canadian Solar does not provide grounding hardware.
- The grounding method described below is recommended by Canadian Solar.

GROUNDING METHOD: BOLT + TOOTHED NUT + CUP WASHER.

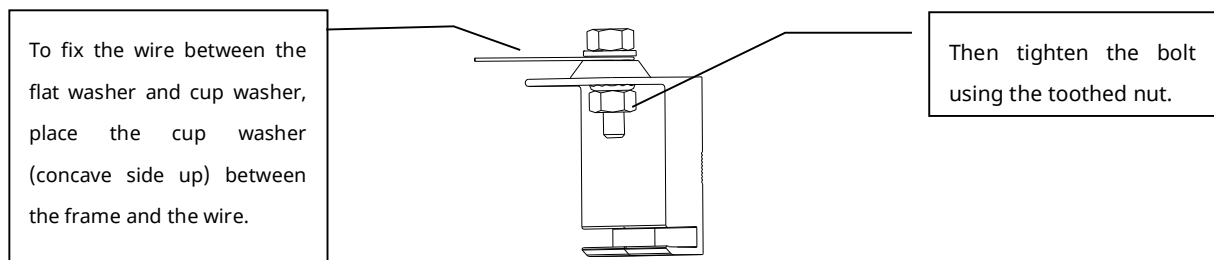

- A grounding kit containing an M5 (3/16") SS cap bolt, an M5 (3/16") SS flat washer, an M5 (3/16") SS cup washer, and an M5 (3/16") SS nut (with teeth) is used to attach copper grounding wire to a pre-drilled grounding hole on the frame (see image above).
- Place the wire between the flat washer and the cup

washer. Ensure that the cup washer is positioned between the frame and the wire with the concave side up to prevent galvanic corrosion. Tighten the bolt securely using the SS toothed nut. A wrench may be used to do this. The tightening torque is 3-7 Nm (2.2-5.2 ft-lbs).

6.0 MOUNTING INSTRUCTIONS



The applicable regulations pertaining to work safety, accident prevention and securing the construction site must be observed. Workers and third party personnel shall wear or install fall arrest equipment. Any third party need to be protected against injuries and damages.

- The mounting design must be certified by a registered professional engineer. The mounting design and procedures must comply with all applicable local codes and requirements from all relevant authorities.
- The module is considered to be in compliance with UL 1703 or UL 61730 and IEC 61215 only when the module is mounted in the manner specified by the mounting instructions included in this installation manual.
- The system designer and installer are responsible for load calculations and for proper design of support structure.
- Any module without a frame (laminated) shall not be considered to comply with the requirements of UL 1703 or UL 61730 unless the module is mounted with hardware that has been tested and evaluated with the module under this standard or by a field Inspection certifying that the installed module complies with the requirements of UL 1703 or UL 61730.
- Canadian Solar does not provide mounting hardware.
- Classic modules can be mounted onto a support structure using one of several approved methods as described below. For information about other installation methods, please contact your local representative. Failure to use a recognized installation method will void the Canadian Solar warranty.
- Use appropriate corrosion-proof fastening materials. All mounting hardware (bolts, spring washers, flat washers, nuts) should be hot dip galvanized or stainless steel.
- Use a torque wrench for installation.
- Do not drill additional holes or modify the module frame. Doing so will void the warranty.
- Classic modules can be installed in either landscape or

portrait orientations. Refer to the detailed instructions for further guidance. Please note that in areas with heavy snowfall (> 2400 Pa) further countermeasures such the use of additional support bars should be considered to avoid snow loads damaging the lowest row of modules.

- In cases where an additional support bar is recommended to improve both mechanical stability and long-term module performance, we recommend selecting a sufficiently resistant material. Canadian Solar recommends bars with a minimum thickness of 50 mm (1.97 in). The support bar centerline should be positioned within 100 mm (3.94 in) of the side frame centerline (slight shifts may be necessary to access module grounding holes).
- The loads described in this manual correspond to test loads. For installations complying with IEC 61215-2:2016 and UL 1703 or UL 61730, a safety factor of 1.5 should be applied for calculating the equivalent maximum authorized design loads. Project design loads depend on construction, applicable standards, location and local climate. Determination of the design loads is the responsibility of the racking suppliers and/or professional engineers. For detailed information, please follow local structural code or contact your professional structural engineer.

6.1 MOUNTING METHOD: BOLTING

- The mechanical load test with these mounting methods were performed according to IEC 61215.
- Modules should be bolted to supporting structures through the mounting holes in the rear frame flanges only.
- Each module must be securely fastened at a minimum of 4 points on two opposite sides.
- M6 X 1 - Grade 8.8 (1/4"-20 Grade B7) bolt and nut should be used.
- The yield strength of bolt and nut should not be less than 450MPa.
- Tightening torques should be 6-9 Nm (4.5-6.6 ft-lbs) for M6 (1/4"-20) coarse thread bolts, depending on bolt

class.

- In areas with heavy wind loads, additional mounting points should be used. The system designer and the installer are responsible for correctly calculating the loads and ensuring that the supporting structure meets all the applicable requirements.

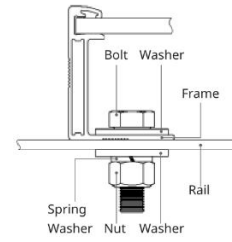

- Modules should be bolted at the following hole locations depending on the configuration and loads:

Table: Approved bolting methods

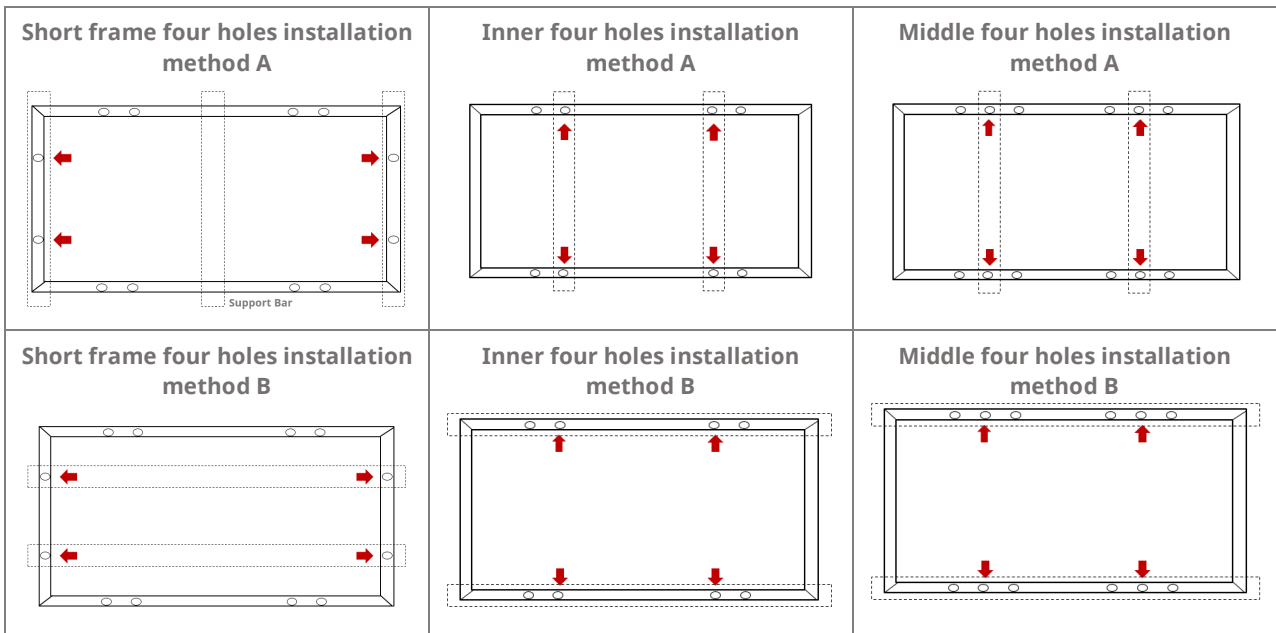

Installation Method Module Types	Short frame four holes installation method A	Short frame four holes installation method B	Inner four holes installation method A	Inner four holes installation method B	Middle four holes installation method A	Middle four holes installation method B
CS6AH CS6A-P-PLUS	+5400Pa/-2400Pa	+2400Pa/-2400Pa	+5400Pa/-2400Pa	+4000Pa/-2400Pa	/	/
CS6PH CS6P-P-PLUS	/	/	+5400Pa/-2400Pa	+4000Pa/-2400Pa	/	/
CS6XH CS6X-P-PLUS	/	/	/	/	+5400Pa/-2400Pa	+5400Pa/-2400Pa

Note: The installation method of bolt is based on the experimental results, “/” means not tested.

6.2 MOUNTING METHOD: CLAMPING

- The mechanical load test with these mounting methods were performed according to IEC 61215.
- Top or bottom clamping methods will vary and are dependent on the mounting structures. Please follow the mounting guidelines recommended by the mounting system supplier.
- Each module must be securely fastened at a minimum of four points on two opposite sides. The clamps should be positioned symmetrically. The clamps should be positioned according to the authorized position ranges.
- Install and tighten the module clamps to the mounting rails using the torque stated by the mounting hardware manufacturer. M6 X 1 (1/4") bolt and nut are used for this clamping method.
- Tightening torques should be within 6~9 Nm (4.5~6.6 ft-lbs) for M6 (1/4") coarse thread bolts, depending on the bolt class. For the bolt grade, the technical guideline from the fastener suppliers should be followed. Different recommendations from specific clamping hardware suppliers should prevail.
- The system designer and installer are responsible for load calculations and for proper design of support structure.
- Canadian Solar's warranty may be void in cases where improper clamps or unsuitable installation methods are found. When installing inter-modules or end-type clamps, please take the following measures into account:

1. Do not bend the module frame.
2. Do not touch or cast shadows on the front glass.
3. Do not damage the surface of the frame (to the exception of the clamps with bonding pins).
4. Ensure the clamps overlap the module frame by at least 5mm (0.2in).
5. Overlap in length by at least
 - a) 80 mm (3.15 in) when uplift load > 2400 Pa is required.
 - b) 40 mm (1.57 in) when uplift load ≤ 2400 Pa is

required.

6. Ensure the clamp thickness is at least 3 mm (0.12 in).

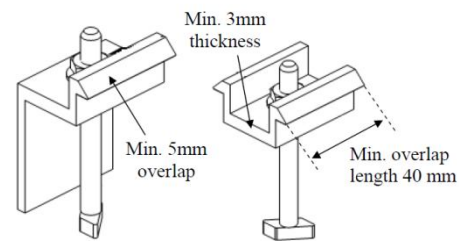

- Clamp material should be anodized aluminum alloy or stainless steel.
- Clamp positions are of crucial importance for the reliability of the installation. The clamp centerlines must only be positioned within the ranges indicated in table below, depending on the configuration and load. For configurations where the mounting rails run parallel to the frame, precautions should be taken to ensure the bottom flange of the module frame overlaps the rail by 15 mm (0.59 in) or more.

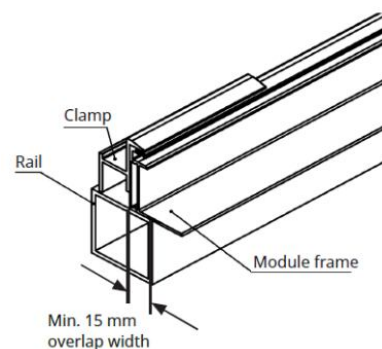

6.2.1 Four clamps on long side of frame and rails perpendicular to the long side frame

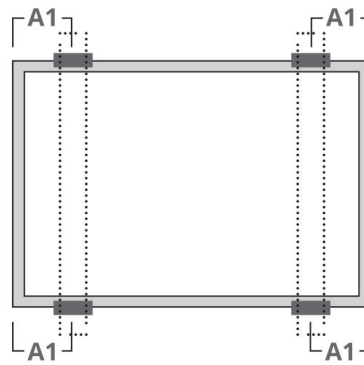

Module Types	Max Mechanical Load (Pa)			
	+2000/ -2000	+2400/ -2400	+5400/ -2400	+5400/ -3600
	A1 Range (mm)			
CS5AH	/	220-380	330-400	/
CS5PH	/	220-390	330-400	/
CS6AH/CS6A-P-PLUS	/	220-440	270-330	/
CS6PH/CS6P-P-PLUS	0-239	331-550	/	240-330
CS6XH/CS6X-P-PLUS	/	340-550	/	410-490

6.2.2 Four clamps on short side of frame and rails perpendicular to the long side frame.

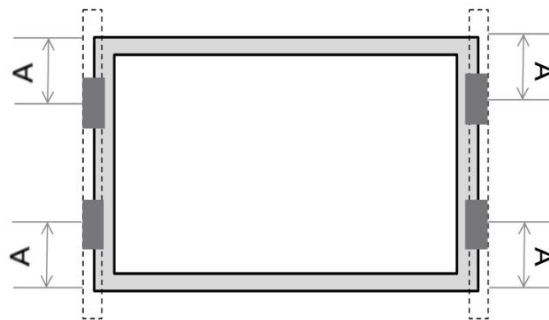

Module Types	A Range (mm)	
	0-200	200-250
	Max Mechanical Load (Pa)	
CS6XH/CS6X-P-PLUS	+1200/-1200	+1400/-1400

6.2.3 Four clamps on long side of frame and rails parallel to the long side frame.

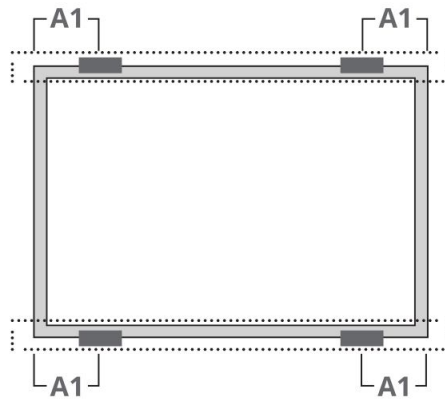

Module Types	Max Mechanical Load (Pa)	
	+4000/-2400	+5400/-2400
	A1 Range (mm)	
CS6PH/CS6P-P-PLUS	240-330	/
CS6XH/CS6X-P-PLUS	/	410-490

6.3 INSERTION SYSTEMS

- This mounting method has been certified by VDE and CSA, or qualified by Canadian Solar.
- Insertion methods can vary and depend on the mounting structures. The installer needs to follow the mounting guidelines recommended by the mounting system supplier. Each module must be securely maintained through all its length on two opposite sides. Install and tighten the insertion profiles to the support structure using the hardware and instructions provided by the mounting system manufacturer. The system designer and installer are solely responsible for load calculations and for the proper design of support structure.
- Canadian Solar warranty may be void in cases where improper insertion systems or unsuitable installation methods are found. When installing insertion profiles, please take the following measures into account:

1. Do not bend the module frame.
2. Do not touch the front glass or cast shadow onto it.
3. Do not damage the surface of the frame.
4. Ensure that the insertion profiles overlap the module frame by at least 10 mm (0.39 in).
5. Ensure that the module frame (C-shape) overlaps the insertion profiles by at least 15 mm (0.59 in).
6. Ensure insertion profile thickness and tolerances suit module thickness.

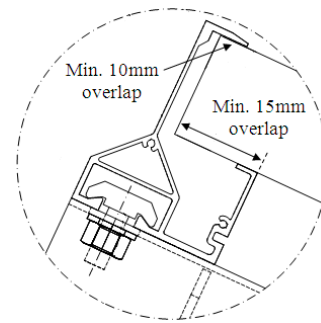

Insertion Method A	Insertion Method B	Insertion Method C
Two insertion profiles run parallel to long side frame.	Two insertion profiles run perpendicularly to long side frame.	An additional support bar used with clamps

Installation Method Module Types	Insertion Method A	Insertion Method B	Insertion Method C
CS6AH/CS6A-P-PLUS	+4000Pa/-2400Pa	+2400Pa/-2400Pa	+5400Pa/-2400Pa
CS6PH/CS6P-P-PLUS	+4000Pa/-2400Pa	+2000Pa/-2000Pa	+5400Pa/-2400Pa
CS6XH/CS6X-P-PLUS	+5400Pa/-2400Pa	+1400Pa/-1400Pa	+5400Pa/-2400Pa

6.4 MOUNTING METHODS WITH SINGLE-AXIS TRACKER

- The bolts, washers and clamps used in this section should follow the requirements in 6.1 and 6.2.
- Under any conditions the junction box should not become in contact with the subjacent racking structure. For any single axis tracker installation method with portrait one row, bearing house cannot be allowed to locate in junction box position.
- If any racking structures, especially bearing house, have to be located under the modules, the gap H between the frame and the racking structure should be at least 25mm.

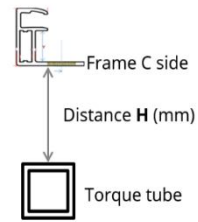

- If your tracker design cannot meet the above distance requirement, please contact Canadian Solar technical support department in writing for advices.

Tracker 1P Clamping method

<p>Overlap width between clamp and frame: Frame top side $\geq 10\text{mm}$ Frame bottom side $\geq 15\text{mm}$</p>	Module type	B Value (mm)	Clamp length C (mm)	Test load (Pa)
	CS6XH-P CS6X-P-PLUS	300	≥ 40	+2400/-2400

The allowable maximum twist angle of the module is 0.5 degree.

- Please contact the tracker manufacturer and Canadian Solar’s technical support department for details in regard to specific projects

7.0 MAINTENANCE

- **Do not** make modifications to any component of the PV module (diode, junction box, connectors or others).
- Regular maintenance is required to keep modules clear of snow, bird droppings, seeds, pollen, leaves, branches, dirt spots, and dust.
- Modules with sufficient tilt (at least 15°), generally may not require cleaning (rain will have a self-cleaning effect). If the module has become soiled, wash with water and a non-abrasive cleaning implement (sponge) during the cool part of the day. Do not scrape or rub dry dirt away, as this may cause micro scratches.
- Snow should be removed using a soft brush.
- Periodically inspect the system to check the integrity of all wiring and supports.
- To protect against electric shock or injury, electrical or mechanical inspections and maintenance should be performed by qualified personnel only.

8.0 MODULE CLEANING GUIDELINES

This manual covers the requirements for the cleaning procedure of Canadian Solar photovoltaic modules. The purpose of these cleaning guidelines is to provide general information for cleaning Canadian Solar modules. System users and professional installers should read these guidelines carefully and strictly follow these instructions.

Failure to follow these instructions may result in death, injury or damage to the photovoltaic modules. Damages induced by inappropriate cleaning procedures will void Canadian Solar warranty.



SAFETY WARNING

- Cleaning activities create risk of damaging the modules and array components, as well as increasing the potential electric shock hazard.
- Cracked or broken modules represent an electric shock hazard due to leakage currents, and the risk of shock is increased when modules are wet. Before cleaning, thoroughly inspect modules for cracks, damage, and loose connections.

- The voltage and current present in an array during daylight hours are sufficient to cause a lethal electrical shock.
- Ensure that the circuit is disconnected before starting the cleaning procedure as contact with leakage of electrically active parts can result in injury.
- Ensure that the array has been disconnected to other active components (such as inverter or combiner boxes) before starting with the cleaning.
- Wear suitable protection (clothes, insulated gloves, etc.).
- **Do not** immerse the module, partially or totally, in water or any other cleaning solution.

HANDLING NOTICE

NOTICE

- Use a proper cleaning solution and suitable cleaning equipment.
- **Do not** use abrasive or electric cleaners on the module.
- Particular attention should be taken to avoid the module backsheet or frame to come in contact with sharp objects, as scratches may directly affect product safety.
- **Do not** use abrasive cleaners, de-greasers or any unauthorized chemical substance (e.g. oil, lubricant, pesticide, etc.) on the module.
- **Do not** use cleaning corrosive solutions containing hydrofluoric acid, alkali, acetone, or industrial alcohol. Only substances explicitly approved by Canadian Solar are allowed to be used for cleaning modules.
- Canadian Solar recommends to avoid rotating brush cleaning methods, as they could create micro-cracks in the PV modules.
- Dirt must never be scraped or rubbed away when dry, as this will cause micro-scratches on the glass surface.

OPERATION PREPARATION

- Noticeable dirt must be rubbed away by gentle cleaning implement (soft cloth, sponge or brush with soft bristles).

- Ensure that brushes or agitating tools are not abrasive to glass, EPDM, silicone, aluminum, or steel.
- Conduct the cleaning activities avoiding the hottest hours of the day, in order to avoid thermal stress on the module.

Canadian Solar recommends the following to be used:

- Water with low mineral content
- Near neutral pH water
- The maximum water pressure recommended is 4 MPa (40 bar)

CLEANING METHODS

Method A: Compressed Air

Canadian Solar recommends cleaning the soft dirt (like dust) on modules just with air pressure. This technique can be applied as long as the method is efficient enough considering the existing conditions.

Method B: Wet cleaning

If excessive soiling is present on the module surface, a non-conductive brush, sponge, or other mild agitating method may be used with caution.

- Ensure that any brushes or agitating tools are constructed with non-conductive materials to minimize risk of electric shock and that they are not abrasive to the glass or the aluminum frame.
- If grease is present, an environmental friendly cleaning agent may be used with caution.

ANNEX A: MECHANICAL AND ELECTRICAL RATINGS

Standard Test Conditions are: Irradiance of 1000 W/m², AM1.5 spectrum, and cell temperature of 25°C. The tolerance of electrical characteristics is respectively within ±3% for Pmax, and ±5% for Isc & Voc. Specifications are subject to change without notice.

Table A: Mechanical and electrical ratings under STC

Model Type	Maximum power Pmax <W>	Operating voltage Vmp <V>	Operating current Imp <A>	Open Circuit Voltage Voc <V>	Short Circuit Current Isc <A>	Max. Series Fuse Rating <A>	Overall Dimension <mm>	Weight <Kg>
CS5AH-180M	180	39.2	4.60	48.0	4.90	15	1595 x 801 x 40/35	15.25
CS5AH-185M	185	39.6	4.68	48.2	4.98	15		
CS5AH-190M	190	40.0	4.76	48.4	5.06	15		
CS5AH-195M	195	40.4	4.83	48.6	5.14	15		
CS5AH-200M	200	40.8	4.91	48.8	5.22	15		
CS5AH-205M	205	41.2	4.99	49.0	5.30	15		
CS5AH-210M	210	41.6	5.07	49.4	5.38	15		
CS5PH-235P	235	50.8	4.63	62.6	4.93	15	1602 x 1061 x 40/35	20.30
CS5PH-240P	240	51.0	4.71	62.8	5.00	15		
CS5PH-245P	245	51.4	4.79	63.0	5.07	15		
CS5PH-250P	250	51.4	4.87	63.2	5.14	15		
CS5PH-255P	255	51.6	4.95	63.4	5.21	15		
CS5PH-260P	260	51.8	5.02	63.6	5.28	15		
CS5PH-250M	250	53.4	4.69	63.4	5.00	15	1602 x 1061 x 40/35	20.30
CS5PH-255M	255	53.6	4.76	63.6	5.06	15		
CS5PH-260M	260	53.8	4.84	63.8	5.13	15		
CS5PH-265M	265	54.0	4.91	64.0	5.20	15		
CS5PH-270M	270	54.2	4.99	64.2	5.27	15		
CS6AH-185P	185	21.8	8.49	25.8	9.48	20	1324 x 982 x 40/35	15.30
CS6AH-190P	190	22.0	8.64	26.1	9.55	20		
CS6AH-195P	195	22.2	8.79	26.4	9.62	20		
CS6AH-200P	200	22.4	8.93	26.7	9.69	20		
CS6AH-205P	205	22.6	9.08	27.0	9.76	20		
CS6AH-210P	210	22.8	9.22	27.3	9.83	20		
CS6AH-215P	215	23.0	9.36	27.6	9.90	20		
CS6AH-220P	220	23.2	9.49	27.9	9.97	20		
CS6AH-220P	220	23.2	9.49	27.9	9.97	20		
CS6AH-215M	215	22.9	9.39	27.8	9.97	20	1324 x 982 x 40/35	15.30
CS6AH-220M	220	23.3	9.45	28.1	10.03	20		
CS6AH-225M	225	23.7	9.50	28.4	10.09	20		

Model Type	Maximum power Pmax <W>	Operating voltage Vmp <V>	Operating current Imp <A>	Open Circuit Voltage Voc <V>	Short Circuit Current Isc <A>	Max. Series Fuse Rating <A>	Overall Dimension <mm>	Weight <Kg>
CS6AH-230M	230	24.1	9.55	28.7	10.15	20		
CS6AH-235M	235	24.5	9.60	29.0	10.21	20		
CS6PH-240P	240	28.2	8.52	33.8	9.41	20	1638 x 982 x 40/35	19.00
CS6PH-245P	245	28.4	8.63	34.0	9.48	20		
CS6PH-250P	250	28.6	8.75	34.2	9.55	20		
CS6PH-255P	255	28.8	8.86	34.4	9.62	20		
CS6PH-260P	260	29.0	8.97	34.6	9.69	20		
CS6PH-265P	265	29.2	9.08	34.8	9.76	20		
CS6PH-270P	270	29.4	9.19	35.0	9.83	20		
CS6PH-275P	275	29.6	9.30	35.2	9.90	20		
CS6PH-280P	280	29.8	9.40	35.4	9.97	20		
CS6PH-280M	280	30.0	9.34	36.5	9.96	20		
CS6PH-285M	285	30.3	9.41	36.7	10.02	20		
CS6PH-290M	290	30.6	9.48	36.9	10.08	20		
CS6PH-295M	295	30.9	9.55	37.1	10.14	20		
CS6PH-300M	300	31.2	9.62	37.3	10.19	20		
CS6PH-305M	305	31.5	9.69	37.5	10.25	20		
CS6PH-310M	310	31.8	9.75	37.7	10.31	20		
CS6XH-345M	345	36.5	9.46	44.4	9.94	20	1954x 982 x 40/35	23.00
CS6XH-350M	350	36.8	9.52	44.6	10.00	20		
CS6XH-355M	355	37.1	9.57	44.8	10.06	20		
CS6XH-360M	360	37.4	9.63	45.0	10.12	20		
CS6XH-365M	365	37.7	9.69	45.2	10.18	20		
CS6XH-370M	370	38.0	9.74	45.4	10.24	20		
CS6XH-375M	375	38.3	9.80	45.6	10.30	20		
CS6XH-295P	295	34.4	8.58	41.4	9.52	20	1954x 982 x 40/35	23.00
CS6XH-300P	300	34.6	8.68	41.6	9.56	20		
CS6XH-305P	305	34.8	8.77	41.8	9.60	20		
CS6XH-310P	310	35.0	8.86	42.0	9.64	20		
CS6XH-315P	315	35.2	8.95	42.2	9.68	20		
CS6XH-320P	320	35.4	9.04	42.4	9.72	20		
CS6XH-325P	325	35.6	9.13	42.6	9.76	20		
CS6XH-330P	330	35.8	9.22	42.8	9.83	20		
CS6XH-335P	335	36.0	9.31	43.0	9.90	20		
CS6XH-340P	340	36.2	9.40	43.2	9.97	20		
CS6XH-345P	345	36.4	9.49	43.4	10.04	20		

Model Type	Maximum power Pmax <W>	Operating voltage Vmp <V>	Operating current Imp <A>	Open Circuit Voltage Voc <V>	Short Circuit Current Isc <A>	Max. Series Fuse Rating <A>	Overall Dimension <mm>	Weight <Kg>
CS5A-200M-PLUS	200	37.9	5.28	45.7	5.66	20A	1595 x 801 x 40/35	15.25
CS5A-205M-PLUS	205	38.1	5.39	45.9	5.74	20A		
CS5A-210M-PLUS	210	38.3	5.49	46.1	5.82	20A		
CS5A-215M-PLUS	215	38.5	5.59	46.3	5.90	20A		
CS5A-220M-PLUS	220	38.7	5.69	46.5	5.98	20A		
CS5P-250M-PLUS	250	47.2	5.30	56.9	5.66	20A	1602 x 1061 x 40/35	19.19
CS5P-255M-PLUS	255	47.4	5.39	57.1	5.74	20A		
CS5P-260M-PLUS	260	47.6	5.47	57.3	5.82	20A		
CS5P-265M-PLUS	265	47.8	5.55	57.5	5.90	20A		
CS5P-270M-PLUS	270	48.0	5.63	57.7	5.98	20A		
CS6A-210P-PLUS	210	24.5	8.58	29.7	9.17	20A	1324 x 982 x 40/35	15.50
CS6A-215P-PLUS	215	24.7	8.71	29.9	9.23	20A		
CS6A-220P-PLUS	220	24.9	8.84	30.1	9.29	20A		
CS6A-225P-PLUS	225	25.1	8.97	30.3	9.42	20A		
CS6A-230P-PLUS	230	25.3	9.10	30.5	9.56	20A		
CS6P-270P-PLUS	270	31.4	8.61	37.9	9.17	20A	1638 x 982 x 40/35	18.00
CS6P-275P-PLUS	275	31.6	8.71	38.1	9.23	20A		
CS6P-280P-PLUS	280	31.8	8.82	38.3	9.29	20A		
CS6P-285P-PLUS	285	32.0	8.92	38.5	9.40	20A		
CS6P-290P-PLUS	290	32.2	9.01	38.7	9.48	20A		
CS6X-330P-PLUS	330	38.7	8.54	46.1	9.17	20A	1954 x 982x 40/35	21.58
CS6X-335P-PLUS	335	38.9	8.62	46.3	9.23	20A		
CS6X-340P-PLUS	340	39.1	8.71	46.5	9.29	20A		
CS6X-345P-PLUS	345	39.3	8.79	46.7	9.35	20A		
CS6X-350P-PLUS	350	39.5	8.87	46.9	9.40	20A		
CS6X-355P-PLUS	355	39.7	8.95	47.1	9.47	20A		

- The recommended maximum series fuse rating is stated in table A above.

AMENDED EDITIONS AND DATES

- Rev 1.0 was amended and released on October, 2020
- Rev 1.1 was amended and released on December, 2020
- Rev 1.2 was amended and released on March, 2021
- Rev 1.3 was amended and released on December, 2021
- Rev 1.31 was amended and released on December, 2021

CSI Solar Co., Ltd.

199 Lushan Road, SND, Suzhou, Jiangsu, China, 215129

www.csisolar.com